



CONVEYOR HANDBOOK

UPDATE August 2021

A member of



Foreword

This "CONVEYOR HANDBOOK" is provided by *FENNER DUNLOP* to allow designers to select the correct specification belting for any particular installation

Properties of fabrics used in Polyester Nylon multi-ply belting constructions are given in detail, while the general properties and application areas of special multi-ply constructions are also shown. Solid woven and steel cord belting are described in detail in separate sections.

The use of various natural and synthetic rubbers with these reinforcements for handling different service conditions is set out for the designer.

Design considerations affecting power demands, belt curves, transitions etc., are provided.

The layout of this manual and its easy approach to belt design will be readily followed by belt design engineers. Should problems arise, the services of *FENNER DUNLOP* are always available to help with any problems in the design, application or operation of conveyor belts.

Index

1. Materials of construction

| | |
|---------------------------------|--------------|
| Reinforcements | 1 - 1 |
| General Properties | 1 - 3 |

2. Belt Capacities

| | |
|--------------------------------------|--------------|
| Capacity Calculations | 2 - 1 |
| Properties of Materials | 2 - 2 |

3. Belt Power and Tensions

| | |
|--|---------------|
| Belt Power Calculations Formulae | 3 - 1 |
| Calculation of Maximum Tensions | 3 - 5 |
| Graduated Idler Spacings | 3 - 7 |
| Feeder Belt Calculations | 3 - 9 |
| Acceleration and Deceleration | 3 - 10 |
| Application of Forces | 3 - 14 |
| Algebraic Signs of Conveyor Forces | 3 - 15 |
| Coasting | 3 - 16 |
| Check List for Large Conveyor Systems | 3 - 17 |

4. Belt Carcass Selection

| | |
|---|--------------|
| Belt Construction Requirements | 4 - 1 |
| Considerations | 4 - 1 |
| Procedure | 4 - 2 |

5. Cover Gauges and Qualities

| | |
|-------------------------------|--------------|
| Considerations..... | 5 - 1 |
| Selection..... | 5 - 1 |
| Pulley side cover..... | 5 - 1 |

6. Pulley Diameters

| | |
|-----------------------------------|--------------|
| Parallel face pulleys..... | 6 - 1 |
| Crown face pulleys..... | 6 - 2 |
| Pulley face width..... | 6 - 2 |

7. Design Considerations

| | |
|--|--------------|
| Multiple Slope and Vertical Curve Conveyors | 7 - 1 |
| Terminal Troughing Idler Arrangements | 7 - 4 |
| Transitions | 7 - 4 |
| Take - Up Arrangements | 7 - 5 |

8. General Data

| | |
|---|--------------|
| Belt Mass and thickness..... | 8 - 1 |
| Shipping dimensions and roll sizes..... | 8 - 1 |
| Length of belt on a roll..... | 8 - 2 |
| Belt transport guidelines..... | 8 - 3 |
| Belt installation and reel sequencing..... | 8 - 4 |

9. Solid Woven Belting

| | |
|---|--------------|
| Belt construction..... | 9 - 1 |
| Belt and cover thickness..... | 9 - 2 |
| Operating temperature range..... | 9 - 3 |
| Operating factor of safety..... | 9 - 3 |
| Safety..... | 9 - 2 |

10. Steel Cord Belting

| | |
|----------------------------------|---------------|
| Belt construction..... | 10 - 1 |
| Operating conditions..... | 10 - 2 |
| Belt covers | 10 - 5 |
| Belt protection | 10 - 5 |
| Splicing | 10 - 6 |

1. Materials of construction

| | |
|---|--------------|
| Reinforcements | 1 – 1 |
| General Properties | 1 – 3 |
| Table 1 Reinforcement Fabrics | 1 – 2 |
| Table 2A Cover Compounds | 1 – 4 |
| Table 2B Heat Resistant Belts | 1 – 5 |
| Table 2C Oil & Chemical Resistant | 1 – 6 |
| Table 2D Fire Resistant & Anti Static Belts | 1 – 7 |

1. Materials of construction

The composition of a conveyor belt can be considered in two parts:

- A. The Carcass, whether ply type (textile) or steel cord construction, which must have sufficient strength to handle the operating tensions and to support the load.
- B. The Covers, which must have the required physical properties and chemical resistance to protect the carcass and give the conveyor belt an economical life span.

The general properties and the application usage of the more economical available reinforcement fabrics and rubber compounds are discussed in this section.

REINFORCEMENTS

Fabrics

Fabrics that are commonly used as reinforcement in conveyor belts are shown in Table 1 of this section

The fabric designation indicates the material used in both warp and weft, e.g. PN signifies that the fabric has Polyester warp fibres and Nylon weft fibres.

The ultimate strength of the belt in kilonewtons per metre width is shown along with the number of plies. PN1000/4 designates a belt with four plies of polyester warp, nylon weft fabric and an ultimate full-belt tensile strength of 1000kN/m. Alternatively the belt can be often described as 4 ply PN250 where the strength of the individual plies is shown.

The allowable working tensions allocated are shown in tables 1 and 2 in section 4.

**TABLE 1.
REINFORCEMENT FABRICS**

| CARCASS TYPE | CARCASS MATERIALS | | STRENGTH RANGE | FEATURES AND APPLICATIONS |
|---|--|---|---|---|
| | WARP (longitudinal) | WEFT (transverse) | kilonewtons per metre width | |
| PN plain weave (DIN code EP) | Polyester | Nylon | 315 to 2000 kN/m (150 to 400 kN/m/ply) | Low elongation. Very good impact resistance Good fastener holding An excellent general purpose fabric. |
| PN crow's foot weave | Polyester | Nylon | 630 to 2500 kN/m (315 to 500 kN/m/ply) | Low elongation Good impact resistance Very good fastener holding. Excellent rip resistance. For high abuse installations |
| PN double weave | Polyester | Nylon | 900 & 1350 kN/m (450 kN/m/ply) | Low elongation. Excellent impact resistance. Excellent fastener holding. For high abuse installations. |
| PP Plain weave | Polyester | Polyester | Up to 900 kN/m (120 & 150 kN/m/ply) | Used in special applications where acid resistance is needed. Contact us for information. |
| NN Plain weave | Nylon | Nylon | Up to 2000 kN/m (150 to 450 kN/m/ply) | High elongation, mostly replaced by polyester-nylon. Used in special applications where low modulus needed or in high pH environment |
| CC Plain weave | Cotton | Cotton | Up to 400 kN/m (65 & 70 kN/m/ply) | Used in special applications such as plasterboard belting and hot pellet handling. |
| SW Solid woven | Nylon/cotton or Polyester/cotton | Nylon/cotton | 600 to 1800kN/m | Main use in underground coal mining. Good fastener holding and impact resistance. Used for bucket elevators. |
| ST Steel cord | Steel cord | None (special reinforcement available) | 500 to 7000 kN/m | Very low elongation and high strength Used for long haul and high-tension applications. |
| AN Aramid nylon (Kevlar) | Polyaramide | Nylon | 630 to 2000 kN/m | Low elongation, high strength, low-weight. Used on high-tension applications and on equipment conveyors. |

PN belting comprises the vast majority of plied fabric belting in service and is referred to throughout this handbook. For information advice on other belting types consult *FENNER DUNLOP*.

GENERAL PROPERTIES OF BELT COVERS AND GRADES

The following tables give a comparison of general characteristics of polymers used in belting compounds.

Special compounding can result in substantial changes to these general polymer properties.

Generally conveyor belts are supplied with electrical resistance in the anti-static range and should not be used for electrical insulation. Special non-conductive grades are available on request.

There are four separate tables:

Belts for Mining, Quarrying and General Service

Heat Resistant belts

Oil and Chemical Resistant grades

Fire Resistant and Anti-static belts

Notes referred to in these tables are:

1. Available with extended ozone resistance capabilities on special request.
2. The low temperature performance figures given in the table are representative of general purpose compounds in each classification. Belts for operation at lower temperatures than those given are available on request.
3. The high temperature performance figures given in the table are representative of situations where the belt is subject to relatively long exposures of blanketing heat. Considerably higher temperature bulk material can often be carried in ventilated situations or where the belt surface can be shielded to some extent by a protective layer of cooled fines.
4. Resist most acids except concentrated strongly oxidising ie., Sulphuric, Nitric and their derivatives. Contact *FENNER DUNLOP* for specific applications.
5. Fire resistant and anti-static grades:
GRADE S meets AS4606 for UNDERGROUND COAL MINING.
GRADE E, F fire resistant and anti-static - mostly for ENCLOSED ABOVE GROUND USE
GRADE K fire retardant and anti-static - meets MSHA 2G and ISO433 requirements
6. Resists most oils however resistance may vary greatly depending on the type of oil.
7. May have poor resistance to oils with low aniline points.

If in doubt, contact *FENNER DUNLOP*

**TABLE 2A – GENERAL PROPERTIES
Mining, Quarrying and General Service**

| FENNER DUNLOP GRADE (Common description) | Grade M, Grade N | Super M MA | Grade A (SAR) | XCG | QuarryMaster |
|--|--|---|---|--|--|
| GENERIC TYPE (Description) | Natural rubber (NR) | Natural rubber (NR) | Natural Rubber Polybutadiene (NR / BR) | Natural Rubber Styrene Butadiene (NR / SBR) | Natural Rubber (NR) |
| APPLICATION | Medium to heavy duty mining and quarrying | Heavy to extreme mining service with lumps & abrasion | Abrasion resistant for fine materials | Cut and gouge resistant for heavy service | Medium to heavy duty mining and quarrying |
| AS1332 BRANDING | M N | Z – SUPER M Z – MA | A | Z – XCG | Z – QUARRYMASTER |
| CO-EFFICIENT OF FRICTION (drive) | GOOD | GOOD | GOOD | GOOD | GOOD |
| WEATHERING/OZONE RESISTANCE | GOOD (1) | GOOD (1) | GOOD (1) | VERY GOOD | GOOD (1) |
| CUT/TEAR RESISTANCE | GOOD to EXCELLENT | GOOD to EXCELLENT | GOOD | GOUGE RESISTANT | GOOD to EXCELLENT |
| ABRASION RESISTANCE | GOOD / VERY GOOD | VERY GOOD / EXCELLENT | EXCELLENT | VERY GOOD | GOOD / VERY GOOD |
| ACID RESISTANCE | GOOD (4) | GOOD (4) | GOOD (4) | GOOD (4) | GOOD (4) |
| MINERAL/OILS | POOR | POOR | POOR | POOR | POOR |
| SERVICE TEMP RANGE (°C) See notes (2) & (3) | - 30 to 70 | - 30 to 70 | - 30 to 70 | - 30 to 70 | - 30 to 70 |
| FLAME RESISTANCE | POOR | POOR | POOR | POOR | POOR |

TABLE 2B – GENERAL PROPERTIES
Heat resistant grades

| FENNER DUNLOP GRADE (Common description) | CRHR | Apex EPT-GP | EPT-Super | HRNR | Hi Temp Nitrile |
|--|---|---|--|--|---------------------------------|
| GENERIC TYPE (Description) | Styrene Butadiene (SBR) | Ethylene Propylene Terpolymer (EPT) | Ethylene Propylene Terpolymer (EPT) | Natural rubber (NR) | Nitrile rubber (NBR) |
| APPLICATION | Heat resistant for lumpy and abrasive materials | Heat resistant for fine materials. Resists hardening and cracking | Maximum heat resistance for fine materials. Resists hardening and cracking | Medium heat resistance. Resists hardening and cracking | Oil and heat resistant |
| AS1332 BRANDING | Z – CRHR | Z – EPT GP | Z – EPT SUPER | Z – HRNR | Z – NITRILE |
| CO-EFFICIENT OF FRICTION (drive) | GOOD | GOOD | GOOD | GOOD | GOOD |
| WEATHERING/OZONE RESISTANCE | FAIR | EXCELLENT | EXCELLENT | GOOD | FAIR |
| CUT/TEAR RESISTANCE | VERY GOOD | FAIR | FAIR | EXCELLENT | VERY GOOD |
| ABRASION RESISTANCE | VERY GOOD | GOOD | GOOD | GOOD | VERY GOOD |
| ACID RESISTANCE | GOOD (4) | VERY GOOD | VERY GOOD | GOOD (4) | GOOD (4) |
| MINERAL/OILS | POOR | POOR | POOR | POOR | VERY GOOD to EXCELLENT (7) |
| SERVICE TEMP RANGE (°C) See notes (2) & (3) | - 10 to 125 (3) | - 20 to 170 (3) | - 20 to 210 (3) | - 20 to 100 (3) | - 10 to 125 (3) |
| FLAME RESISTANCE | POOR | POOR | POOR | POOR | POOR |

TABLE 2C – GENERAL PROPERTIES
Oil and chemical resistant grades

| FENNER DUNLOP GRADE (Common description) | Hi Temp Nitrile | ORS Neoprene | PVC Nitrile | SOR | K, SOR | EPT-GP |
|--|-----------------------------|----------------------|---|---|---|--|
| GENERIC TYPE (Description) | Nitrile rubber (NBR) | Neoprene (CR) | Nitrile PVC (NBR / PVC) | Nitrile rubber Styrene Butadiene (NBR/SBR) | Nitrile rubber Styrene Butadiene (NBR / SBR) | Ethylene Propylene Terpolymer (EPT) |
| APPLICATION | Oil and heat resistant | Oil resistant | Oil resistant mostly for grain handling and fertilizer production | Medium oil resistance mostly for grain & wood chip handling | Medium oil & fire resistance used for grain and wood chip | Heat, weathering and acid resistant |
| AS1332 BRANDING | Z – NITRILE | Z – ORS | Z – PVC NITRILE | Z – SOR | K, Z – SOR | Z – EPT GP |
| CO-EFFICIENT OF FRICTION (drive) | GOOD | GOOD | FAIR | GOOD | FAIR | GOOD |
| WEATHERING/OZONE RESISTANCE | FAIR | GOOD | VERY GOOD | FAIR / GOOD | FAIR | EXCELLENT |
| CUT/TEAR RESISTANCE | VERY GOOD | GOOD | GOOD | GOOD | GOOD | FAIR |
| ABRASION RESISTANCE | VERY GOOD | GOOD | VERY GOOD | GOOD | GOOD | GOOD |
| ACID RESISTANCE | GOOD (4) | GOOD (4) | GOOD (4) | GOOD (4) | GOOD (4) | VERY GOOD |
| MINERAL/OILS | VERY GOOD TO EXCELLENT (7) | VERY GOOD (6) | VERY GOOD (7) | GOOD (6) | GOOD (6) | POOR |
| SERVICE TEMP RANGE (°C) See notes (2) & (3) | - 10 to 125 | - 10 to 110 | - 10 to 120 | - 20 to 70 | - 20 to 70 | - 20 to 170 |
| FLAME RESISTANCE | POOR | GOOD | POOR | POOR | GOOD | POOR |

**TABLE 2D – GENERAL PROPERTIES
Fire Resistant and Anti-static belts**

| FENNER DUNLOP GRADE (Common description) | Underground FRAS S,D Above ground FRAS D,E,F Above ground FRAS K,D | Grade K MSHA Sugar FRAS | K-SOR (Oil Resistant Grade K) | FRAS PVC | Grade E Anti-Static |
|---|---|---|---|--|--------------------------------|
| GENERIC TYPE (Description) | Neoprene (CR) | Natural rubber Styrene Butadiene Polybutadiene (NR / SBR / BR) | Nitrile rubber Styrene Butadiene (NBR / SBR) | PVC | Natural Rubber (NR) |
| APPLICATION | Generally for enclosed hazardous environs – coal, grain etc. | Sugar and grain industries, coal handling | Medium oil & fire resistance used for grain and wood chips | Solid woven belt for coal mining underground | Grain handling |
| AS1332 BRANDING | S,D D,E,F, K,D (See Note 5) | K,Z - AR (See Note 5) | K, Z - SOR (See Note 5) | S (See Note 5) | E |
| CO-EFFICIENT OF FRICTION (drive) | GOOD | GOOD | FAIR | FAIR | GOOD |
| WEATHERING/OZONE RESISTANCE | VERY GOOD | GOOD (1) | FAIR | FAIR | GOOD (1) |
| CUT/TEAR RESISTANCE | VERY GOOD | GOOD | GOOD | FAIR | GOOD to EXCELLENT |
| ABRASION RESISTANCE | EXCELLENT | VERY GOOD | GOOD | VERY GOOD | GOOD / VERY GOOD |
| ACID RESISTANCE | GOOD (4) | GOOD (4) | GOOD (4) | GOOD (4) | GOOD (4) |
| MINERAL/OILS | GOOD (6) | POOR | GOOD (6) | GOOD | POOR |
| SERVICE TEMP RANGE (°C) See notes (2) & (3) | - 10 to 100 | - 30 to 70 | - 20 to 70 | - 15 to 90 | - 30 to 70 |
| FLAME RESISTANCE | EXCELLENT | GOOD | GOOD | EXCELLENT | POOR |

2. Belt Capacities

| | |
|---|--------------|
| Capacity Calculations | 2 – 2 |
| Properties of Materials | 2 – 6 |
| Table 1 Capacity Factor – three equal roll trough idlers | 2 – 2 |
| Table 2 Cosines | 2 – 2 |
| Table 3 Capacity of Troughed Belts - three equal roll trough idlers | 2 – 3 |
| Table 4 Capacity of Troughed Belts - five equal roll trough idlers | 2 – 4 |
| Table 5 Maximum Lump Size Recommended for Various Belt Widths | 2 – 5 |
| Table 6 Typical Belt Speeds in General Use | 2 – 5 |
| Table 7 Properties of Materials | 2 – 6 |
| Table 8 Conveyor Maximum Slope Angles | 2 – 8 |

2. Belt capacities

For maximum haulage efficiency, conveyors should be operated fully loaded at maximum recommended speed.

Belt capacity is dependent upon these inter-related factors:

Belt width

Minimum belt width may be influenced by loading or transfer point requirements, or by material lump size and fines mix– refer to Table 5. Troughability and load support restrictions (refer section 4), will also influence final belt width selection

Belt speed

Possible belt speed is influenced by many factors, importantly the loading, discharge and transfer arrangements, maintenance standards, lump sizes etc. Typical belt speeds are shown in Table 6.

Material bulk density and surcharge angle

Due to undulations of the belt passing over the conveyor idlers, the natural angle of repose of the material is decreased. This decreased angle known as ANGLE OF SURCHARGE is one of the most important characteristics in determining carrying capacity as it directly governs the cross sectional area of material on the belt and hence the "volume" being conveyed.

Table 7 shows bulk density and surcharge angles for some common materials. With materials which slump readily, such as fine powders or dust, or on long conveyors where the load may settle, consideration should be given to using a reduced surcharge angle for capacity determination, and may require the compensatory use of other factors (such as greater belt width or speed) to provide the required capacity.

Inclination angle

The angle of inclination of a conveyor changes the carrying capacity. The load cross-section area of an inclined load is reduced when viewed in a vertical plane as the surcharge angle is reduced perpendicular to the belt. An approximation of the reduced capacity can be determined by multiplying the horizontal capacity by the Cosine of the inclination angle (see Table 2). Table 8 shows maximum inclination angle for some common materials. Effectively the capacity reduction is usually less than 3%.

Troughing angle

For standard 3 roll idlers, the most common trough angle is 35° although trough angles from 20° to 45° are not uncommon. Steeper trough angles give increased capacity but can have consequences for convex and concave curves and transition zones.

Idler configuration

The most common configuration for idler rollers is 3 rolls of equal length. This configuration and normal clearances are shown in FIG. 1 below.

Other configurations from flat belt to 5 roll idlers and with unequal roll lengths are sometimes used. For wide belts, 5 roll suspended idlers are not uncommon and Table 4 shows capacity for different trough and surcharge angles.

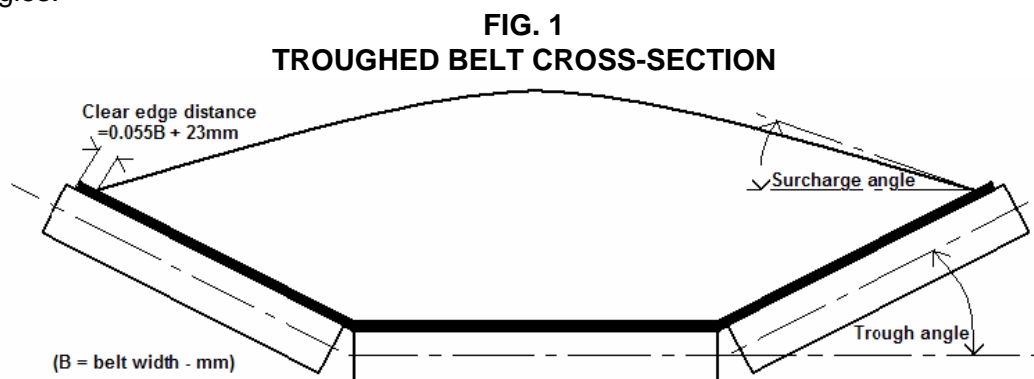

CAPACITY CALCULATIONS

General formula:

The general formula for capacity is:

$$\text{Capacity - tonnes per hour} = 3.6 \times \text{Load Cross Section Area}^* (\text{m}^2) \times \text{Belt Speed (m/s)} \times \text{Material Density (kg/m}^3) \dots\dots\dots (2.1)$$

(* perpendicular to the belt)

For common idler configurations:

Capacity can be determined using the tables provided:

Table 3 of this section has been designed for quick reference and give the capacities of conveyors from 400 mm to 2200 mm wide, assuming the use of 3 roll equal length idlers at 35° troughing angle and an average material surcharge angle of 20° and bulk density of 1000kg/m³. Capacities for conveyors using other troughing angles or materials can be obtained by multiplying the capacity shown in Table 3 by the appropriate CAPACITY FACTOR obtained from Table 1 below.

3 equal roll idlers:

$$\text{Capacity - tonnes per hour} = \text{Capacity (Table 3)} \times \text{Material Density (kg/m}^3) \times \text{Capacity factor (Table 1)} \times \text{Belt Speed (m/s)} / 1000 \dots (2.2)$$

5 equal roll idlers:

$$\text{Capacity - tonnes per hour} = \text{Capacity (Table 4)} \times \text{Material Density (kg/m}^3) \times \text{Belt Speed (m/s)} / 1000 \dots\dots\dots (2.3)$$

**TABLE 1
CAPACITY FACTOR – THREE EQUAL ROLL TROUGH IDLERS**

| Surcharge angle | Idler troughing angle | | | | |
|-----------------|-----------------------|------|------|------|------|
| | 20° | 25° | 30° | 35° | 45° |
| 0° | 0.43 | 0.53 | 0.61 | 0.69 | 0.81 |
| 5° | 0.52 | 0.61 | 0.69 | 0.77 | 0.88 |
| 10° | 0.61 | 0.70 | 0.77 | 0.84 | 0.94 |
| 15° | 0.70 | 0.78 | 0.86 | 0.92 | 1.04 |
| 20° | 0.79 | 0.87 | 0.94 | 1.00 | 1.08 |
| 25° | 0.88 | 0.96 | 1.03 | 1.08 | 1.15 |

For inclined or declined conveyors, multiply the above by the Cosine of the inclination angle, below:

**TABLE 2
COSINES**

| Inclination angle | 0° | 5° | 10° | 15° | 17.5° | 20° | 22.5° | 25° |
|-------------------|-------|-------|-------|-------|-------|-------|-------|-------|
| Cosine | 1.000 | 0.996 | 0.985 | 0.966 | 0.954 | 0.940 | 0.924 | 0.906 |

TABLE 3
CAPACITY OF TROUGHED BELTS FOR
THREE ROLL EQUAL LENGTH IDLERS

Material bulk density: 1000 kilograms per cubic metre
Surcharge angle: 20 degrees
35 degree trough angle

| Belt width | Belt speed - metres per second | | | | | | | | | | | |
|------------|--------------------------------|------|------|------|------|------|------|------|------|------|------|-------|
| | 0.5 | 0.75 | 1 | 1.25 | 1.5 | 2 | 2.5 | 3 | 3.5 | 4 | 4.5 | 5 |
| 400mm | 26 | 39 | 52 | 65 | 78 | 104 | 130 | 156 | 182 | 209 | 235 | 261 |
| 450mm | 34 | 51 | 69 | 86 | 103 | 137 | 172 | 206 | 240 | 274 | 309 | 343 |
| 500mm | 44 | 65 | 87 | 109 | 131 | 175 | 218 | 262 | 306 | 349 | 393 | 437 |
| 600mm | 66 | 99 | 131 | 164 | 197 | 263 | 329 | 394 | 460 | 526 | 592 | 657 |
| 650mm | 78 | 118 | 157 | 196 | 235 | 314 | 392 | 471 | 549 | 628 | 706 | 785 |
| 750mm | 107 | 161 | 215 | 268 | 322 | 429 | 536 | 644 | 751 | 858 | 965 | 1073 |
| 800mm | 123 | 185 | 247 | 308 | 370 | 493 | 617 | 740 | 863 | 987 | 1110 | 1233 |
| 900mm | 159 | 238 | 318 | 397 | 477 | 635 | 794 | 953 | 1112 | 1271 | 1430 | 1589 |
| 1000mm | 199 | 298 | 398 | 497 | 597 | 795 | 994 | 1193 | 1392 | 1591 | 1790 | 1989 |
| 1050mm | 221 | 331 | 441 | 551 | 662 | 882 | 1103 | 1323 | 1544 | 1764 | 1985 | 2206 |
| 1200mm | 292 | 438 | 585 | 731 | 877 | 1169 | 1462 | 1754 | 2046 | 2339 | 2631 | 2923 |
| 1350mm | 374 | 561 | 748 | 936 | 1123 | 1497 | 1871 | 2245 | 2619 | 2994 | 3368 | 3742 |
| 1400mm | 404 | 606 | 807 | 1009 | 1211 | 1615 | 2019 | 2422 | 2826 | 3230 | 3634 | 4037 |
| 1500mm | 466 | 699 | 932 | 1165 | 1398 | 1865 | 2331 | 2797 | 3263 | 3729 | 4195 | 4662 |
| 1600mm | 533 | 800 | 1066 | 1333 | 1599 | 2132 | 2665 | 3198 | 3731 | 4265 | 4798 | 5331 |
| 1800mm | 680 | 1020 | 1361 | 1701 | 2041 | 2721 | 3402 | 4082 | 4762 | 5443 | 6123 | 6803 |
| 2000mm | 846 | 1268 | 1691 | 2114 | 2537 | 3382 | 4228 | 5073 | 5919 | 6764 | 7610 | 8455 |
| 2200mm | 1029 | 1543 | 2057 | 2572 | 3086 | 4115 | 5143 | 6172 | 7201 | 8229 | 9258 | 10287 |

For other trough and surcharge angles, multiply the above capacities by the Capacity Factor shown in Table 1.

TABLE 4**CAPACITY OF TROUGHED BELTS FOR
FIVE ROLL EQUAL LENGTH IDLERS**

**Belt speed 1.0 metre per second
Material bulk density: 1000 kilograms per cubic metre**

TROUGH ANGLE: 45 Degrees

| Belt width | Surcharge angle | | | | |
|------------|-----------------|------|------|------|------|
| | 5° | 10° | 15° | 20° | 25° |
| 1400mm | 780 | 850 | 920 | 990 | 1060 |
| 1500mm | 890 | 970 | 1050 | 1130 | 1210 |
| 1600mm | 1010 | 1100 | 1190 | 1280 | 1370 |
| 1800mm | 1270 | 1380 | 1490 | 1610 | 1730 |
| 2000mm | 1560 | 1690 | 1830 | 1970 | 2120 |
| 2200mm | 1920 | 2090 | 2260 | 2430 | 2610 |
| 2400mm | 2320 | 2530 | 2730 | 2940 | 3150 |
| 2600mm | 2770 | 3000 | 3240 | 3490 | 3740 |
| 2800mm | 3240 | 3520 | 3800 | 4090 | 4380 |

TROUGH ANGLE: 55 Degrees

| Belt width | Surcharge angle | | | | |
|------------|-----------------|------|------|------|------|
| | 5° | 10° | 15° | 20° | 25° |
| 1400mm | 870 | 930 | 990 | 1050 | 1110 |
| 1500mm | 990 | 1060 | 1130 | 1200 | 1270 |
| 1600mm | 1120 | 1200 | 1280 | 1360 | 1440 |
| 1800mm | 1410 | 1510 | 1600 | 1700 | 1810 |
| 2000mm | 1730 | 1850 | 1970 | 2090 | 2220 |
| 2200mm | 2130 | 3600 | 2430 | 2580 | 2730 |
| 2400mm | 2580 | 2750 | 2930 | 3110 | 3290 |
| 2600mm | 3060 | 3270 | 3480 | 3690 | 3910 |
| 2800mm | 3590 | 3830 | 4080 | 4320 | 4580 |

TROUGH ANGLE: 60 Degrees

| Belt width | Surcharge angle | | | | |
|------------|-----------------|------|------|------|------|
| | 5° | 10° | 15° | 20° | 25° |
| 1400mm | 900 | 950 | 1010 | 1060 | 1120 |
| 1500mm | 1020 | 1090 | 1150 | 1220 | 1280 |
| 1600mm | 1160 | 1230 | 1300 | 1380 | 1450 |
| 1800mm | 1460 | 1550 | 1640 | 1730 | 1820 |
| 2000mm | 1790 | 1900 | 2010 | 2120 | 2240 |
| 2200mm | 2210 | 3600 | 2470 | 2610 | 2750 |
| 2400mm | 2660 | 2820 | 2990 | 3150 | 3320 |
| 2600mm | 3170 | 3350 | 3540 | 3740 | 3940 |
| 2800mm | 3710 | 3930 | 4150 | 4380 | 4610 |

**TABLE 5
MAXIMUM RECOMMENDED LUMP SIZE FOR BELT WIDTH**

| Belt width (mm) | If Uniform lumps (mm) | If mixed with approx. 80% fines (mm) |
|----------------------------|----------------------------------|---|
| 400 | 75 | 125 |
| 450 | 100 | 150 |
| 500 | 100 | 175 |
| 600 | 125 | 200 |
| 650 | 125 | 250 |
| 750 | 150 | 300 |
| 800 | 150 | 300 |
| 900 | 175 | 325 |
| 1000 | 200 | 375 |
| 1050 | 200 | 375 |
| 1200 | 300 | 450 |
| 1350 | 300 | 500 |
| 1400 | 300 | 600 |
| 1500 | 350 | 600 |
| 1600 | 375 | 600 |
| 1800 | 450 | 600 |
| 2000 | 450 | 600 |
| 2200 | 475 | 650 |

**TABLE 6
TYPICAL BELT SPEEDS IN GENERAL USE (meters per second)**

| Belt width (mm) | Grain or free flowing materials | Run-of-mine, crushed coal and earth | Hard ores and stone |
|----------------------------|--|--|--------------------------------|
| 400 | 2.0 | 1.5 | - |
| 450 | 2.5 | 2.25 | 1.75 |
| 500 | 3.0 | 2.25 | 1.75 |
| 600 | 3.0 | 2.5 | 2.25 |
| 650 | 3.25 | 2.75 | 2.50 |
| 750 | 3.5 | 3.0 - 3.5 | 2.75 |
| 800 | 3.75 | 3.0 - 3.5 | 2.75 |
| 900 | 4.0 | 3.0 - 3.5 | 3.0 |
| 1000 | 4.0 | 3.0 - 3.5 | 3.0 |
| 1050 | 4.0 | 3.0 - 3.5 | 3.0 |
| 1200 | 4.0 | 3.25 - 4.0 | 3.0 - 3.5 |
| 1350 | 4.5 | 3.25 - 4.0 | 3.0 - 3.5 |
| 1400 | 4.5 | 3.25 - 4.0 | 3.0 - 3.5 |
| 1500 | 4.5 | 3.25 - 4.0 | 3.0 - 3.5 |
| 1600 | 5.0 | 3.75 - 4.25 | 3.25 - 4.0 |
| 1800 | 5.0 | 3.75 - 4.25 | 3.25 - 4.0 |
| 2000 | - | 3.75 - 4.25 | 3.25 - 4.0 |
| 2200 | - | 3.75 - 4.25 | - |

NOTE: There is a world wide tendency to use increased belt speeds wherever possible. For example, brown coal is handled at speeds over 7.5 m/s and in Australia, iron ore at speeds over 5 m/s. Such higher speeds and those shown under run-of -mine coal, crushed coal and earth in the above table demand special attention to the design and maintenance of loading, transfer and discharge points.

PROPERTIES OF MATERIALS

Typical densities, angles of repose and surcharge angles for various materials are shown in Table 7 below.

For many materials these factors are subject to considerable variation, depending on the moisture content, lump size, cohesive properties, etc. Unless otherwise stated, the Tables refer to dry weight conditions, based usually on broken materials in sizes most commonly found in conveyor systems.

The physical characteristics of the material affect the operating parameters of the belt in other ways, for example, typical belt speeds, recommended maximum lump sizes, maximum slope if the belt is inclined, etc.,. Reference is made to these factors in Tables 5, 6 & 8 of this section.

Where the material to be conveyed has unusual slumping characteristics, or where sufficient water is present to provide lubrication between the belt cover and the material, the slope angles to be used would be appreciably below those listed and should be determined by test or from experience in the field.

Moulded cleats can be used to raise permissible slope angles where otherwise slipping of the load on the belt would be experienced – refer to FENNER DUNLOP for advice.

**TABLE 7
PROPERTIES OF MATERIALS**

| Material | Density (kg/m ³) | Angle of repose | Angle of surcharge |
|----------------------------------|------------------------------|-----------------|--------------------|
| Acid phosphate | 1540 | * | * |
| Alumina | 800-960 | 22° | 5° |
| Alum - lump | 800-960 | 27° | * |
| - pulverized | 720-800 | 35° | * |
| Ashes, boiler-house - dry, loose | 560-690 | 38°- 45° | 25 |
| Asphalt | 1280-1360 | * | * |
| Bagasse - fresh, moist | 120 | * | 25° |
| - dry, loose | 80 | * | 25° |
| Barytes - 50-75mm lumps | 2320-2400 | 30° | 25° |
| - 15mm screenings | 2080-2320 | 30° | 20° |
| - dust | 1760-2080 | 30° | 15° |
| Basalt - 50-75mm lumps | 1680-1760 | * | 25° |
| - 15mm screenings | 2080-2320 | * | 20° |
| - dust | 1760-2080 | * | 15° |
| Bauxite - crushed | 1200-1360 | 30°- 35° | 5°- 15° |
| Borax, solid - 50-100mm lumps | 960-1040 | 40° | * |
| - 40-50mm lumps | 880-960 | 30°- 45° | * |
| Brewers grain - dry | 400-480 | 45° | * |
| - wet | 880-960 | 45° | * |
| Brick - hard | 2000 | 30°- 45° | * |
| - soft | 1600 | 30°- 45° | * |
| Carbon black - powder | 80 | * | * |
| - pellets | 400 | 40° | * |
| Cement, Portland - loose | 1200-1360 | 40° | 20° |
| - clinker | 1280-1520 | 33° | 25° |
| - slurry | 1440 | * | 5° |
| Chalk - 50-75mm lumps | 1280-1360 | 45° | * |
| - 40-50mm lumps | 1200-1280 | 40°- 45° | * |
| Char - sugar refinery | 720 | * | * |

| Material | Density (kg/m ³) | Angle of repose | Angle of surcharge |
|--|------------------------------|-----------------|--------------------|
| Chips, paper mill - <i>softwood</i> | 190-480 | * | 25° |
| - <i>yellow pine</i> | 320-400 | * | 25° |
| Clay - dry, loose | 1010-1440 | 40°- 45° | 15°- 25° |
| - <i>brick, ground fine</i> | 1760 | 35° | 15° |
| Coal - 150mm domestic sizes | 830-900 | * | 25° |
| - <i>run-of-mine</i> | 720-880 | 35° | 25° |
| - <i>slack</i> | 690-800 | 37° | 25° |
| - <i>pulverized for coking</i> | 480-590 | * | 10° |
| - <i>lignite, broken</i> | 720-880 | * | 25° |
| Cocoa | 480-560 | * | * |
| Coke - run of oven | 400-480 | 30° | 25° |
| - <i>breeze</i> | 380-560 | 30°- 45° | 20° |
| Concrete, wet, on conveyor | 1760-2400 | * | 5° |
| Copper ores, crushed | 2080-2400 | * | 25° |
| Copra | 350 | * | * |
| Corn grits | 670 | * | * |
| Cryolite - 50-75mm lumps | 1600-1680 | * | 20° |
| - 15mm screenings | 1440-1600 | * | 15° |
| - <i>dust</i> | 1200-1440 | * | 5° |
| Dolomite - <i>lump</i> | 1440-1600 | See limestone | * |
| Earth - <i>as excavated, dry</i> | 1120-1280 | 30°- 45° | 20°- 25° |
| - <i>wet, mud</i> | 1600-1760 | * | 5° |
| Foundry refuse, old sand, cores, etc. | 960-1280 | * | 15° |
| Garbage - <i>household</i> | 800 | * | * |
| Glass - <i>batch</i> | 1680 | * | * |
| - <i>broken</i> | 1280-1600 | * | * |
| Granite - 40-50mm lumps | 1360-1440 | 25° | * |
| - 15mm screenings | 1280-1440 | * | * |
| - <i>broken</i> | 1520-1600 | * | * |
| Gravel - <i>dry, sharp</i> | 1440-1600 | 30°- 45° | 25° |
| - <i>wet</i> | 1600-1920 | 32° | 25° |
| Gutta percha | 960 | * | * |
| Gypsum - 50-75mm lumps | 1200-1280 | 30° | 20° |
| -15mm screenings | 1120-1280 | 40° | 15° |
| - <i>dust</i> | 960-1120 | 42° | * |
| Hops - <i>brewery and moist</i> | 560 | 30°- 45° | * |
| Ice - <i>crushed</i> | 640 | * | * |
| Iron borings - <i>machine shop</i> | 2000 | * | * |
| Iron ores, <i>depends on iron percentage</i> | 1600-3200 | 35° | 25° |
| Iron pyrites - 50-75mm lumps | 2160-2320 | * | 20° |
| - 15mm screenings | 1920-2160 | * | 15° |
| - <i>dust</i> | 1680-1920 | * | 5° |
| Lead ores, <i>depends on lead percentage</i> | 3200-4320 | 30° | 15° |
| Limestone - 50-75mm lumps | 1440-1520 | 30°- 40° | 25° |
| -1 5mm screenings | 1280-1440 | * | 15° |
| - <i>dust</i> | 1200-1280 | * | 5° |
| Linseed cake - <i>crushed</i> | 760-780 | * | * |
| Manganese ore | 2000-2240 | 39° | * |
| Malt meal | 570-640 | * | * |
| Meal | 700 | * | * |
| Paper pulp | 640-960 | * | 5° |
| Petroleum coke | 560-640 | * | * |
| Phosphate rock | 1360 | * | * |
| Pitch | 1150 | * | * |
| Quartz, <i>solid - 50-75mm lumps</i> | 1440-1520 | 35° | * |

| Material | Density (kg/m ³) | Angle of repose | Angle of surcharge |
|-----------------------------------|------------------------------|-----------------|--------------------|
| - 40-50mm lumps | 1360-1440 | 35° | * |
| - dust | 1120-1280 | 40° | * |
| Rock, soft, excavated with shovel | 1600-1760 | * | 20° |
| Rubber | 930 | * | * |
| Rubber - reclaim | 560 | * | * |
| Salt - coarse | 640-900 | * | 25° |
| - fines | 720 | 25° | 5° |
| - lump for stock | 1600 | * | 25° |
| Sand - beach or river, wet | 1600-2080 | 15°- 30° | 5°- 15° |
| - dry | 1440-1600 | 34°- 45° | 15° |
| - foundry, loose | 1280-1440 | * | 15° |
| - foundry, rammed lumps | 1600-1760 | * | 10° |
| Sandstone | 1360-1440 | * | * |
| Sawdust | 160-200 | 35° | * |
| Shale - broken | 1440-1600 | * | * |
| - crushed | 1360-1440 | 39° | * |
| Slag - blast furnace, crushed | 1280-1440 | 25° | 25° |
| - granulated, dry | 960-1040 | 25° | 10° |
| -granulated, wet | 1440-1600 | 45° | 10° |
| Slate - 40-75mm lumps | 1360-1520 | * | * |
| - 15mm screenings | 1280-1440 | 28° | * |
| Soda ash | 800-1040 | 32° | * |
| Sugar cane stalks | 400 | * | * |
| Sugar - raw | 880-1040 | 37° | * |
| - refined | 880 | * | * |
| Sulphur - 50-75mm lumps | 1360-1440 | 35° | 25° |
| - 15mm screenings | 1200-1360 | * | 15° |
| Talc - solid | 2640 | * | * |
| - 50-75mm lumps | 1440-1520 | * | * |
| - dust | 1220-1280 | * | * |
| Turf - dry | 480 | * | * |
| Wheat | 720-770 | 28° | 10° |
| Zinc ores, crushed | 2400-2560 | 38° | 20° |
| Zinc oxide - light | 160-480 | * | 10° |
| - heavy | 480-560 | * | 10° |

**TABLE 8
CONVEYOR MAXIMUM SLOPE ANGLES WITH VARIOUS MATERIALS**

| Material | Maximum slope angle |
|-------------------------------------|---------------------|
| Bituminous coal - <i>ROM</i> | 18° |
| Bituminous coal - <i>sized</i> | 15°- 16° |
| Bituminous coal - <i>slack</i> | 20° |
| Brown coal - <i>ROM</i> | 18° |
| Cement, <i>Portland - loose</i> | 20° |
| Clay - <i>fine and dry</i> | 22° |
| Clay - <i>wet lump</i> | 18° |
| Coke - <i>screened</i> | 15°- 16° |
| Coke - <i>breeze</i> | 20° |
| Concrete - <i>normal</i> | 15° |
| Concrete - <i>wet</i> | 10°- 12° |
| Earth - <i>loose and dry</i> | 18- 20° |
| Grains | 15° |
| Gravel - <i>washed</i> | 12°- 15° |
| Gravel and sand | 18°- 20° |
| Gravel and sand - <i>wet</i> | 20°- 22° |
| Lime - <i>powdered</i> | 22° |
| Ores - <i>finest only</i> | 20° |
| Ores - <i>mixed lumps and fines</i> | 18° |
| Ores - <i>sized</i> | 16° |
| Rock - <i>finest only</i> | 20° |
| Rock - <i>mixed lumps and fines</i> | 18° |
| Rock - <i>sized</i> | 16° |
| Sand - <i>damp</i> | 18°- 20° |
| Sand - <i>dry</i> | 15° |
| Sulphur - <i>powdered</i> | 22° |
| Wood chips | 23°- 25° |

For drift conveyors out of coal mines handling R.O.M. bituminous coal, slope angles of 15°- 16° are more commonly chosen than the permissible 18°.

3. Belt Power and Tensions

| | |
|--|---------------|
| Belt Power Calculations Formulae | 3 - 1 |
| Calculation of Maximum Tensions | 3 - 5 |
| Graduated Idler Spacings | 3 - 7 |
| Feeder Belt Calculations | 3 - 9 |
| Acceleration and Deceleration | 3 - 10 |
| Application of Forces | 3 - 14 |
| Algebraic Signs of Conveyor Forces | 3 - 15 |
| Coasting | 3 - 16 |
| Check List for Large Conveyor Systems | 3 - 17 |
| | |
| Table 1 Standard Drive Factor 'K' Values | 3 - 3 |
| Table 2 Special Drive Factor 'K' Values | 3 - 4 |
| Table 3 Average Values for 'Q' for Fabric Belts (Mass of Moving Parts) | 3 - 4 |
| Table 4 Recommended Average Carrying Idler Spacing | 3 - 7 |
| Table 5 Belt Tensions Required at Low Tension Zones to Restrict Sag to 2% of Idler Spacing | 3 - 8 |
| Table 6 Graduated Carrying Idler Spacing Guide | 3 - 8 |
| Table 7 Conveyor Starting Methods and Their Classifications | 3 - 10 |
| Table 8 Recommended Drive and Take-up Locations With Counterweight Reaction | 3 - 12 |
| Table 9 Requirement for Brake or Anti-Roll Back Devices | 3 - 13 |
| Table 10 Typical Acceleration Values | 3 - 15 |

3. Belt power and tensions

BELT POWER CALCULATION FORMULAE

Power requirements for belt conveyors may be calculated from the following formulae:

$$\text{Power} = \frac{F_c (L + t_f) (C + 3.6 QS)}{367} \pm \frac{CH}{367} \quad (\text{kW}) \dots\dots\dots (3.1)$$

or
$$\text{Power} = \frac{F_e (L + t_f) 3.6 QS}{367} + \frac{F_l (L + t_f) C}{367} \pm \frac{CH}{367} \quad (\text{kW}) \dots\dots\dots (3.2)$$

Where:

- F_c, F_e, F_l = Equipment friction factors – refer item (1) below.
- L = Horizontal centre to centre distance (m).
- t_f = Terminal friction constant expressed in metres – refer item (2) below.
- C = Capacity (t/h).
- Q = Mass of moving parts expressed in kilograms per metre of centre to centre distance (refer Table 3, Section 3, Page 3-4).
- S = Belt speed (m/s).
- H = Nett change in elevation (m).
- K = Drive factor dependent on pulley surface, arc of contact and type of tensioning (refer Tables 1 and 2 of this section)

The values of the main factors and constants are as follows:

(1) Equipment friction factors:

- (a) On short centre conveyors using best quality equipment, it is often more convenient to use an average equipment friction factor (F_c) of .0225 for horizontal and inclined conveyors and .0135 on decline regenerative systems.
- (b) On many systems, such as portable conveyors, "Chevron" steep angle conveyors and temporary installations using anti-friction bearings, the following value for equipment friction will apply:
 $F_c = .030$.
- (c) On longer centre conveyors and individual component tension calculations as detailed below, equipment friction factors F_e and F_l are used for empty and loaded belt conditions respectively, thus:
 - (i) Horizontal and elevating conveyors
 $F_e = .020$ for empty calculations
 $F_l = .025$ for load calculations
 - (ii) Regenerative decline conveyors
 $F_e = .010$ for empty calculations
 $F_l = .017$ for load calculations

(2) Terminal friction constant, t_f , expressed in metres of centre to centre distance:

- (a) Horizontal and elevating conveyors
 - (i) Up to 300 m centres = 60 m
 - (ii) From 300 m to 1200 m = 45 m
 - (iii) From 1200 m to 1800 m = 30 m
 - (iv) Above 1800 m this influence is disregarded.

(b) Regenerative decline conveyors

$$t_f = 90 \text{ m}$$

(c) On the systems as described in para. (1)(b), i.e., where

$$F_c = .030$$

$t_f = 45 \text{ m}$ (except for "Chevron" belt conveyors, where values as in (2)(a) are used.

(d) On rare occasions it is possible to find long centre belts that are slightly regenerative under loaded conditions, but require more power for the empty belt. When this condition is met the terminal friction allowance is varied as follows for empty tension calculations only:

$$t_f = 260 \text{ m.}$$

Additional friction considerations. Where the number of pulleys is large in relation to the length of the conveyor, e.g., multi-tripper conveyors, it is necessary to make allowance for the additional tension required to overcome these pulley frictions.

Also where skirt board lengths are long in relation to conveyor length, allowance should be made for the additional friction involved.

Component frictions and tensions. Should it be necessary to calculate individual component tensions for the assembly of tension diagrams on multiple slope conveyors, or for assessment of the effects of acceleration or deceleration on a particular system, the following formulae will apply:

Return side friction

$$= F_e \times Q \times L \times 0.4 \times (9.81 \times 10^{-3}) \text{ (kN)} \dots\dots\dots (3.3)$$

Total empty friction

$$= F_e (L + t_f) Q \times (9.81 \times 10^{-3}) \text{ (kN)} \dots\dots\dots (3.4)$$

Carrying side empty friction

$$= \text{Total empty friction} - \text{return side friction (kN)} \dots\dots\dots (3.5)$$

Load friction

$$= F_l (L + t_f) \frac{C}{3.6S} \times (9.81 \times 10^{-3}) \text{ (kN)} \dots\dots\dots (3.6)$$

Load slope tension

$$= \pm \frac{CH}{3.6S} \times (9.81 \times 10^{-3}) \text{ (kN)} \dots\dots\dots (3.7)$$

Belt slope tension

$$= \pm B \times H \times (9.81 \times 10^{-3}) \text{ (kN)} \dots\dots\dots (3.8)$$

where B is the belt weight per lineal metre (refer to Section 8), and all other symbols are as given previously.

Effective tension, $T_e = \text{Total empty friction} + \text{load friction} + \text{load slope tension}$

$$= \left[F_e (L + t_f) Q + F_l (L + t_f) \frac{C}{3.6S} \pm \frac{CH}{3.6S} \right] 9.81 \times 10^{-3} \text{ (kN)} \dots\dots\dots (3.9)$$

$$\text{Slack side tension } T_2 = T_e \times K \text{ (kN)} \dots\dots\dots (3.10)$$

where K is the drive factor dependent on pulley surface, arc of contact and method of tensioning, listed in Tables 1 and 2 of this section.

Power is simply calculated from T_e by:

$$\text{Power} = T_e \times S \text{ (kW)} \dots\dots\dots (3.11a)$$

and

$$T_e = \frac{\text{kW}}{S} \text{ (kN)} \dots\dots\dots (3.11b)$$

**TABLE 1
STANDARD DRIVE FACTOR "K" VALUES**

| ARC OF CONTACT (Degrees) | COUNTERWEIGHT TAKE-UP | | SCREW TAKE-UP | |
|-----------------------------|-----------------------------|-------------------------------|-------------------------------------|---------------------------------------|
| | Bare pulley $\mu = 0.30$ | Lagged pulley $\mu = 0.35$ | Bare pulley For 20% higher T_1 | Lagged pulley For 20% higher T_1 |
| Single pulley | | | | |
| *180 | 0.64 | 0.50 | 0.97 | 0.90 |
| *210 | 0.50 | 0.38 | 0.80 | 0.66 |
| *220 | 0.46 | 0.35 | 0.76 | 0.63 |
| *230 | 0.43 | 0.32 | 0.72 | 0.59 |
| *240 | 0.40 | 0.30 | 0.68 | 0.56 |
| 270 | 0.32 | 0.24 | 0.58 | 0.49 |
| Tandem Pulley | | | | |
| 360 | 0.18 | 0.13 | 0.42 | 0.36 |
| 390 | 0.15 | 0.11 | 0.39 | 0.33 |
| *420 | 0.13 | 0.09 | 0.36 | 0.31 |
| *440 | 0.11 | 0.07 | 0.34 | 0.30 |
| *450 | 0.11 | 0.07 | 0.33 | 0.29 |
| *460 | 0.09 | 0.06 | 0.32 | 0.29 |
| 480 | 0.09 | 0.06 | 0.31 | 0.27 |

* Arc of contact commonly met in actual practice

The above values are calculated from the basic tension relationship formula:

$$\frac{T_1}{T_2} = e^{\mu\theta} \dots\dots\dots (3.12)$$

Where:

- T_1 = Tight side tension
- T_2 = Slack side tension
- e = Napierian logarithm base
- μ = Coefficient of friction
- θ = Arc of contact in radians

The "K" values in Table 1 are calculated from:

$$K = \frac{1}{e^{\mu\theta} - 1}$$

Coefficient of friction, bare pulley, dry conditions:

$$\mu = 0.30$$

Coefficient of friction, lagged pulley, dry conditions:

$$\mu = 0.35$$

Coefficient of friction, lagged and grooved pulley, wet or dry conditions:

$$\mu = 0.35$$

TABLE 2
SPECIAL DRIVE FACTOR "K" VALUES
For varying friction coefficient (μ) and counterweight take-up

| ARC OF CONTACT (Degrees) | $\mu = 0.15$ | $\mu = 0.20$ | $\mu = 0.25$ |
|-----------------------------|--------------|--------------|--------------|
| Single pulley | | | |
| 180 | 1.66 | 1.14 | 0.84 |
| 210 | 1.36 | 0.93 | 0.67 |
| 220 | 1.28 | 0.87 | 0.62 |
| 230 | 1.21 | 0.81 | 0.58 |
| 240 | 1.15 | 0.76 | 0.54 |
| Tandem pulley | | | |
| 360 | 0.64 | 0.40 | 0.26 |
| 390 | 0.56 | 0.35 | 0.22 |
| 420 | 0.50 | 0.30 | 0.19 |
| 440 | 0.46 | 0.27 | 0.17 |
| 450 | 0.45 | 0.26 | 0.16 |
| 460 | 0.43 | 0.25 | 0.16 |
| 480 | 0.40 | 0.23 | 0.14 |

NOTE:
For design purposes with Apex "Blue Ribbon" solid woven belting, use "K" values for $\mu = 0.30$ on lagged pulleys, and $\mu = 0.25$ on bare pulleys.

TABLE 3
AVERAGE VALUES FOR "Q" FOR FABRIC BELTS
(MASS OF MOVING PARTS, KILOGRAMS PER METRE)

| Belt width (mm) | Idler diameter | | | |
|--------------------|----------------|--------|--------|--------|
| | 102 mm | 127 mm | 152 mm | 178 mm |
| 300 | — | — | — | — |
| 350 | 18 | 19 | — | — |
| 400 | 21 | 23 | — | — |
| 450 | 22 | 26 | — | — |
| 500 | 24 | 29 | 35 | — |
| 600 | 30 | 34 | 41 | — |
| 650 | 33 | 40 | 47 | — |
| 750 | 36 | 46 | 52 | — |
| 800 | 39 | 49 | 53 | — |
| 900 | 45 | 54 | 64 | 86 |
| 1000 | 50 | 59 | 68 | 100 |
| 1050 | 52 | 61 | 70 | 107 |
| 1200 | — | 70 | 84 | 125 |
| 1350 | — | — | 100 | 143 |
| 1400 | — | — | 103 | 150 |
| 1500 | — | — | 110 | 164 |
| 1600 | — | — | 118 | 175 |
| 1800 | — | — | 133 | 196 |
| 2000 | — | — | 148 | 217 |

The mass of belting and idler spacing obviously affect the above values considerably and therefore this table gives conservative and average figures only. For closer determination each individual installation should be checked using the following formula, and taking into consideration belt mass, type of idler, and idler spacing:

$$Q = 2B + \frac{w_t}{s_1} + \frac{w_r}{s_2} \quad (\text{kg/m}) \dots\dots\dots (3.13)$$

where:

- B = Belt mass in kilograms per lineal meter, refer Section 8.
 - w_t = Mass of moving parts of troughing idler (kg).
 - w_r = Mass of moving parts of return idler (kg).
 - s₁ = Spacing of troughing idlers (m).
 - s₂ = Spacing of return idlers (m).
-] from idler manufacturers

“Q” values for steel cord applications should always be calculated accurately using above formula.

CALCULATION OF MAXIMUM TENSIONS

Because of the different types of belt arrangement which may be required to suit a particular application, various basic formulae are needed to determine the maximum tension, expressed in kilonewtons.

The main components of the maximum operating tension, T_{max}, are:

- T_e = Effective tension (kN)
- T₂ = Slack side tension (kN)
- T_{sag} = See Note (3), page 6 of this section.

1. Horizontal belts

$$T_{max} = T_e + T_2 \dots\dots\dots (3.14)$$

2. Inclined belts

*(a) Drive at Head Pulley

$$T_{max} = T_e + T_2 \dots\dots\dots (3.15)$$

or

$$T_{max} = T_e + \text{belt slope tension} - \text{return side friction} + T_{sag} \dots\dots\dots (3.16)$$

(b) Drive at Tail Pulley

$$T_{max} = T_e + T_2 \dots\dots\dots (3.17)$$

or

$$T_{max} = T_e + T_2 + \text{belt slope tension} - \text{return side friction} \dots\dots\dots (3.18)$$

3. Decline belts

*(a) Regenerative Belt – Tail Drive

$$T_{max} = T_e + T_2 \dots\dots\dots (3.19)$$

or

$$T_{max} = T_e + \text{belt slope tension} + \text{return side friction} + T_{sag} \dots\dots\dots (3.20)$$

(b) Regenerative Belt – Head Drive

$$T_{max} = T_e + T_2 + \text{belt slope tension} + \text{return side friction} \dots\dots\dots (3.21)$$

(c) Partially regenerative – Head Drive

$$T_{max} = T_e + T_2 \dots\dots\dots (3.22)$$

or

$$T_{max} = T_2 + \text{belt slope tension} + \text{return side friction} \dots\dots\dots (3.23)$$

(d) Partially regenerative – Tail Drive

$$T_{max} = T_e + T_2 \dots\dots\dots (3.24)$$

or

$$T_{max} = \text{Belt slope tension} + \text{return side friction} + T_{sag} \dots\dots\dots (3.25)$$

NOTE:

- (1) Wherever two formulae appear appropriate, use the larger of the two values obtained.
- (2) *Drive positions marked with an asterisk are those generally preferred for good operating conditions on the conveyor types suggested.
- (3) T_{sag} is the tension necessary in the conveyor system to prevent excess belt sag. The value of T_{sag} selected must take into account the belt construction, material mass and idler spacing. Table 5 of this section will assist in arriving at this figure. At points in high lift or contour following systems, little or no tension may exist. These points may be found by graphical methods. Counterweight tension may need to be increased to provide sufficient tension in the system to ensure that belt tension does not fall below T_{sag} in these low tension areas.

FIG. 1. BELTS AND PULLEY ARRANGEMENTS

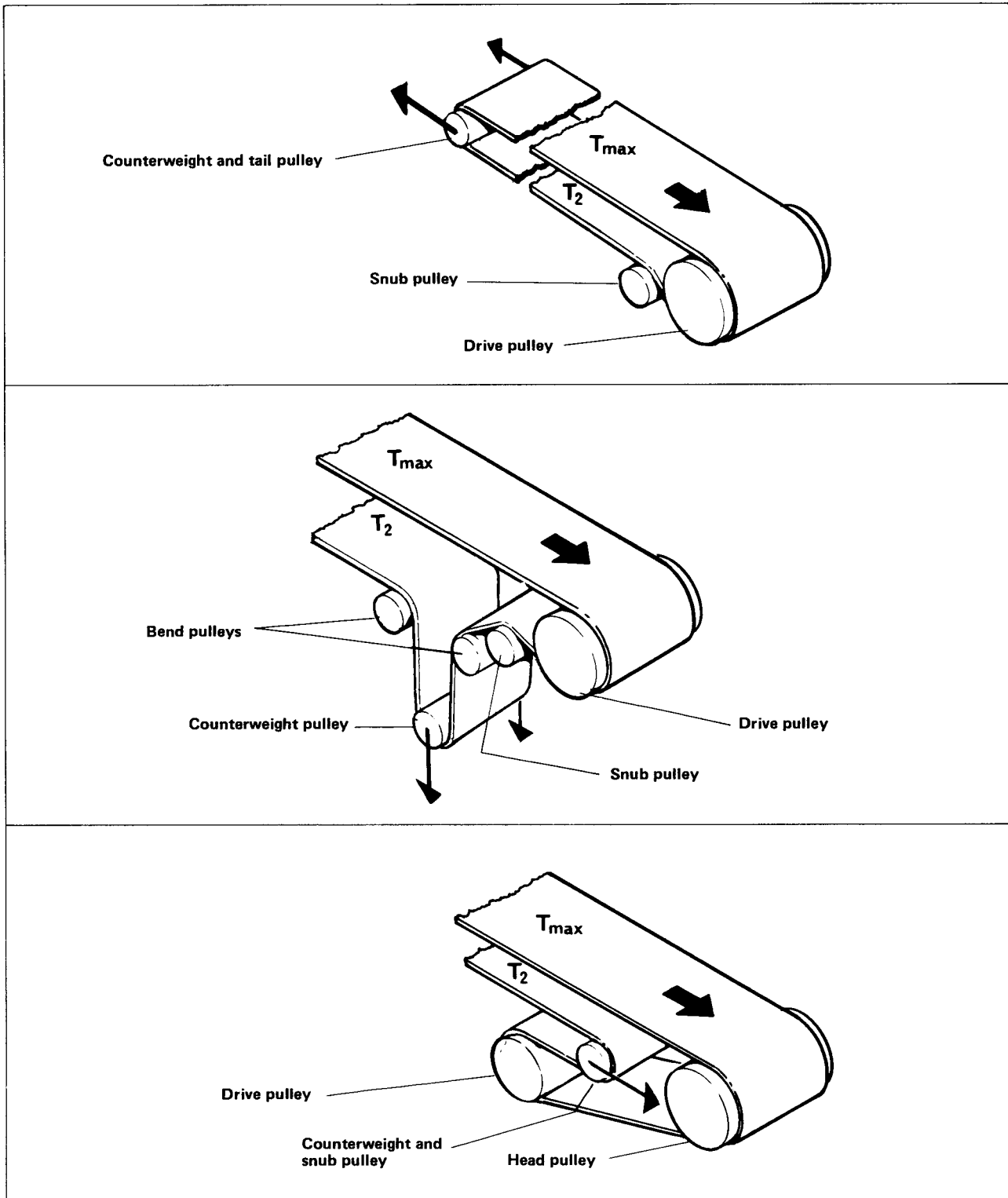

IDLER SPACINGS

TABLE 4
RECOMMENDED AVERAGE CARRYING IDLER SPACING (METRES)

| Belt width (mm) | Material density – kilograms per cubic metre | | | | | |
|--------------------|--|-----|------|------|------|------|
| | 480 | 800 | 1200 | 1600 | 2000 | 2400 |
| 300–400 | 1.7 | 1.7 | 1.5 | – | – | – |
| 450–500 | 1.7 | 1.7 | 1.5 | 1.5 | – | – |
| 600 | 1.7 | 1.7 | 1.5 | 1.5 | 1.4 | 1.0 |
| 650 | 1.5 | 1.5 | 1.4 | 1.4 | 1.3 | 1.0 |
| 750 | 1.5 | 1.5 | 1.4 | 1.4 | 1.3 | 1.0 |
| 800 | 1.5 | 1.5 | 1.4 | 1.4 | 1.2 | 1.0 |
| 900 | 1.5 | 1.5 | 1.4 | 1.4 | 1.2 | 1.0 |
| 1000 | 1.5 | 1.4 | 1.2 | 1.2 | 1.0 | 1.0 |
| 1050 | 1.5 | 1.4 | 1.2 | 1.2 | 1.0 | 0.9 |
| 1200 | 1.5 | 1.4 | 1.0 | 1.0 | 0.9 | 0.8 |
| 1350 | 1.4 | 1.2 | 0.9 | 0.9 | 0.8 | 0.8 |
| 1400 | 1.2 | 1.2 | 0.9 | 0.9 | 0.8 | 0.8 |
| 1500 | 1.2 | 1.2 | 0.9 | 0.9 | 0.8 | 0.8 |
| 1600 | 1.2 | 1.2 | 0.8 | 0.8 | 0.8 | 0.6 |
| 1700 | 1.2 | 1.2 | 0.8 | 0.8 | 0.8 | 0.6 |
| 1800 | 1.2 | 1.2 | 0.8 | 0.8 | 0.8 | 0.6 |
| 2000 | 1.2 | 1.2 | 0.8 | 0.8 | 0.8 | 0.6 |

GRADUATED IDLER SPACINGS

On long centre, heavily loaded, high tension conveyor systems, it is possible to use graduated idler spacings. The sag will vary inversely with the tension in the belt. Since the tension varies along the length of the belt the spacing can be graduated, being smallest at the zone of low tension and increasing as the belt tension increases. Savings can thus be effected on both the carrying and return runs. The spacing at any point can be obtained from the formula:

$$\text{Idler spacing} = \frac{8 \times T \times \text{sag}}{M_l \times (9.81 \times 10^{-3})} \text{ (m)} \dots\dots\dots (3.26)$$

where:

M_l = Mass of belt and live load expressed in kilograms per metre.

T = Tension at the point being investigated (kN).

sag = A percentage of the idler spacing expressed as a decimal and usually 0.02 (2%).

$$\text{Live load} = \frac{C}{3.6S} \text{ (kg/m)} \dots\dots\dots (3.27)$$

where:

S = Belt speed (m/s)

C = Capacity (t/h)

The figures given in Table 5 of this section will give a quick check. When the conveyor is on a uniform gradient the graduated idler spacings in Table 6 of this section will be of assistance in determining a graduated system.

NOTE: Care should be taken to check belt tensions under all possible load conditions before installing idlers at graduated spacings. Idlers installed at spacings determined by maximum load tension calculations could cause operating problems through excess belt sag under lightly loaded conditions.

TABLE 5
BELT TENSIONS (kN) REQUIRED AT LOW TENSION ZONES
TO RESTRICT SAG TO 2% OF IDLER SPACING

| Idler spacing (metres) | Mass of belt and load (kilograms per metre run) | | | | | | | | |
|------------------------|---|------|-------|-------|-------|-------|-------|-------|-------|
| | 35 | 75 | 110 | 150 | 185 | 225 | 260 | 300 | 335 |
| 0.30 | 0.69 | 1.38 | 2.07 | 2.76 | 3.45 | 4.14 | 4.83 | 5.25 | 6.20 |
| 0.45 | 1.05 | 2.09 | 3.14 | 4.18 | 5.23 | 6.27 | 7.32 | 8.36 | 9.41 |
| 0.60 | 1.38 | 2.76 | 4.14 | 5.52 | 6.89 | 8.27 | 9.65 | 11.03 | 12.41 |
| 0.75 | 1.73 | 3.47 | 5.20 | 6.94 | 8.67 | 10.41 | 12.14 | 13.88 | 15.61 |
| 0.90 | 2.09 | 4.18 | 6.27 | 8.36 | 10.45 | 12.54 | 14.63 | 16.72 | 18.81 |
| 1.00 | 2.42 | 4.85 | 7.27 | 9.70 | 12.12 | 14.54 | 16.97 | 19.39 | 21.82 |
| 1.20 | 2.78 | 5.56 | 8.34 | 11.12 | 13.90 | 16.68 | 19.46 | 22.24 | 25.02 |
| 1.40 | 3.14 | 6.27 | 9.41 | 12.54 | 15.68 | 18.82 | 21.95 | 25.09 | 28.22 |
| 1.50 | 3.47 | 6.94 | 10.41 | 13.88 | 17.35 | 20.82 | 24.29 | 27.76 | 31.22 |
| 1.70 | 3.83 | 7.65 | 11.48 | 15.30 | 19.13 | 22.95 | 26.78 | 30.60 | 34.43 |
| 1.80 | 4.16 | 8.32 | 12.48 | 16.64 | 20.79 | 24.95 | 29.11 | 33.27 | 37.43 |
| 2.00 | 4.51 | 9.03 | 13.54 | 18.06 | 22.57 | 27.09 | 31.60 | 36.12 | 40.63 |
| 2.10 | 4.87 | 9.74 | 14.61 | 19.48 | 24.35 | 29.22 | 34.09 | 38.96 | 43.84 |

The belt tension values given above in kilonewtons are calculated from the theoretical sag formula for a flat belt, but they are generally used for inclined idler rolls. These figures are therefore conservative when applied to a troughed belt because of the added resistance to sag resulting from the beam effect of the troughing.

TABLE 6
GRADUATED CARRYING IDLER SPACING GUIDE

| Overall average idler spacing (m) (Refer Table 4) | Actual idler spacing (m) in zones of conveyor centre distance (shown in percentages) working from low tension end of unit | | | | |
|--|---|-------|--------|--------|---------|
| | 0-5% | 5-15% | 15-30% | 30-65% | 65-100% |
| 0.9 | 0.46 | 0.61 | 0.84 | 0.99 | 1.22 |
| 1.0 | 0.53 | 0.76 | 0.99 | 1.14 | 1.37 |
| 1.2 | 0.61 | 0.84 | 1.07 | 1.37 | 1.60 |
| 1.4 | 0.69 | 0.99 | 1.22 | 1.52 | 1.83 |
| 1.5 | 0.76 | 1.07 | 1.37 | 1.68 | 1.98 |
| 1.7 | 0.84 | 1.14 | 1.52 | 1.83 | 2.13 |

Supplementary notes:

- (1) Return idler spacing = approximately 3.0 metres.
- (2) Impact idler spacing = approximately ¼ to ½ carrying idler spacing.
- (3) Convex curve idler spacing – at most ½ carrying and return idler spacing.
- (4) Self aligning idlers – one or two sets for the return side of belt approaching tail pulley at 6 m to 9 m intervals from the pulley. Also useful at times on the carrying side approaching head pulleys and along the whole carrying and return runs at approximately 120 m and 60 m respectively.

FEEDER BELT CALCULATIONS

The following sub-section applies to fully skirted feeder belts.

Belt speeds. For feeder belts supported by idlers, belt speeds should not exceed 0.25 m/s with abrasive materials and 0.5 m/s with non-abrasive materials. For slider bed support it is usual not to exceed 0.13 m/s.

Feeder belt capacity. For: width of skirted load = 80% of belt width
depth of skirted load = 40% of skirted load width (flat belts)

$$\text{Capacity} = \frac{W^2 \times M \times S}{1.085} \text{ (t/h)} \dots\dots\dots (3.28)$$

where:

- W = Belt width (m)
- M = Material density (kg/m³)
- S = Belt speed (m/s)

Feeder belt tensions and power. The effective height of load in the hopper supported by the belt can be assumed as twice the loaded belt width for most lumped bulk materials; thus the mass of the load supported by and to be moved by the belt is, approximately:

$$\text{Mass} = 2W_{\ell}^2 \times L_{\ell} \times M \text{ (kg)} \dots\dots\dots (3.29)$$

where:

- W_ℓ = Hopper opening width (m)
- L_ℓ = Hopper opening length (m)
- M = Material density (kg/m³)

$$\text{Effective Belt Tension, } T_e = \mu_o \times 2W_{\ell}^2 \times L_{\ell} \times M \times (9.81 \times 10^{-3}) \text{ (kN)} \dots\dots\dots (3.30)$$

where:

- μ_o = Overall friction coefficient
(0.4 for idler operation)
(0.6 for slider bed operation)
(up to 1.0 for difficult flow materials)

$$\text{Maximum belt tension, } T_{\max} = (1 + K) T_e \text{ (kN)} \dots\dots\dots (3.31)$$

where:

- K = Drive factor
(0.97 for 180° wrap, screw take-up, bare steel pulley);
(0.90 for 180° wrap, screw take-up, lagged pulley);
(other values from Tables 1 and 2 of this section)

$$\text{Belt power} = T_e \times S \text{ (kW)} \dots\dots\dots (3.32)$$

where:

- S = Belt speed (m/s)

Note: Height of hopper opening above belt should not be less than three times maximum lump size.

Feeder belt specification. For carcass design as per Section 4, Page 1, the following considerations apply:

- (a) Carcass: low elongation, high strength carcass preferred — such as KN or PN constructions;
- (b) Top covers: usually from 5 mm thick for lumps up to 50 mm, to 10 mm thick for lumps up to 150 mm;
- (c) Bottom covers: 2 to 4 mm thick depending on degree of abrasion and impact.

ACCELERATION AND DECELERATION

(a) Accelerating Belt Conveyors

The ideal starting arrangement for a belt conveyor is one which provides a gradual stepless increase in torque, which rises to a value just sufficient to put the belt in motion. Once this is achieved there should be a slight pause to allow shock tensions within the system to dampen out. Following this the drive should continue the stepless increase in torque at a faster rate until full speed is reached.

The question of cost must always be considered and generally there is some compromise in choice of motor and controller. The following table lists most, but not necessarily all, methods that can be regarded as acceptable, and classifies them in respect of ideal starting arrangements for the belt.

With D.O.L. starting of normal squirrel cage motors, it is often possible to start a conveyor and not harm the belt in any way, particularly on short centre installations, because the inertia of the driving components is in excess of the load and thus the torque transmitted to the belt is quite often below the customary limit of 150 – 160% of the running torque.

As necessary, D.O.L. starting characteristics are modified with the substitution of primary resistance or auto-transformer starters.

TABLE 7
CONVEYOR STARTING METHODS AND THEIR CLASSIFICATION

| Motor type | Classification | | | |
|-------------------------------|--|---|---|----------------|
| | Class 1 start | Class 2 start | Class 3 start | Class 4 start |
| Normal squirrel cage | D.O.L. starter with scoop-type hydraulic coupling having torque acceleration control device. D.O.L. starter with eddy current clutch. | | D.O.L. starter with traction type fluid coupling, "dry fluid" coupling or centrifugal clutch. | D.O.L. starter |
| Special purpose squirrel cage | | | D.O.L. starter. | |
| Wound rotor or slip ring | Primary-secondary resistance starter with or without hydraulic coupling and brake. Motor driven drum controller starting. | Automatic secondary resistance starter. | | |

(b) Decelerating Belt Conveyors

Regenerative decline conveyors. If an induction motor is driven by its load in the same direction as the rotation of its flux, its speed rises above synchronous speed. The motor acts as an induction generator, taking magnetising current from the line and absorbing mechanical power through its shaft. Electric power is then fed back into the power system. The motor will restrain the load with little rise in speed above synchronous as long as the load torque does not exceed the maximum torque of the motor. If maximum torque is exceeded the motor becomes unstable and runs away.

Since the motor draws magnetising current from the line it follows that no dynamic braking is possible when the connection between the motor starter and the power line is interrupted. A decline conveyor is an excellent illustration of this effect when the speed of the belt and load are restrained by the motor. The motor serves as a generator feeding power back into the system without special control.

Regenerative braking at speeds below synchronous is not possible. Retardation must be affected by other braking methods and the brake selected for a regenerative decline conveyor must have the following characteristics:

- (i) It must always fail safe.
- (ii) It must stop the conveyor in a reasonable time so that there will be no damage to the belt, the driving components or the brake itself.
- (iii) When the brake stops the conveyor, or it fails safe, it must have sufficient torque rating to hold the conveyor motionless under fully loaded conditions of operation.

Decline conveyors may therefore be stopped by any one of the following means:

- (i) Dynamic braking
- (ii) Eddy current braking
- (iii) Hydraulically
- (iv) Friction braking

It is, of course, possible to use a combination of the above methods but the only brake that will fail safe and hold the load is the friction type. As a result, the most common type of brake used as a control on decline conveyors is the gravity or spring actuated thrustor brake.

Many factors have to be considered in the selection of brake size of sufficient torque to decelerate the load and hold it motionless. Problems such as gradual deceleration and the heating effect on the drum shoes have also to be considered. The inertia of the driving components will also have a marked effect and therefore these brakes must always be designed on a most liberal basis.

Horizontal conveyors. When power is interrupted on long-centre horizontal conveyors, "drift" or "coasting" will take place because of the inertia of the system. Normally this condition is not troublesome unless the long-centre belt is one of a multiple system or is feeding onto a shorter inclined belt with vastly different natural deceleration characteristics.

Unless such conveyors are braked, material may pile up at transfer points with the possibility of damage to both belt and machinery. If the natural deceleration time is excessive for the system, retardation may be affected by the use of dynamic or eddy current braking.

(c) **Hold Back or Anti-Run Devices**

When an inclined conveyor is stopped under load, the force of gravity will tend to drive the belt in the reverse direction. A hold-back device is necessary to prevent the belt backing down the incline. A reversal of motion would cause spillage and, in many cases, belt and mechanical damage. The following list details the most commonly used types:

- (i) Clutch type hold-backs. These are among the safest devices and consist of an over-running clutch with its outer race held stationary between two lever arms rigidly mounted to the outer housing. These clutch-type hold-backs are considerably more expensive than other devices but they require the lowest maintenance and operate with zero back-lash on the drive shaft. They come in a wide variety of sizes, have high capacities and cannot be contaminated by dust.
- (ii) Roller type hold-back. These consist of hardened steel rollers which lie in wedge-shaped slots as long as the hold-back rotor is running in the direction of normal travel. Once the direction of rotation is reversed, the rollers jam in the narrow end of the slots holding the rotor against the stationary housing.
- (iii) Ratchet and pawl hold-backs. These are the simplest and least expensive type of hold-back. Their simplicity of design promotes easy maintenance but unless serviced regularly, dust and lack of lubrication could make the device ineffective. Such units should always be covered if mounted in dusty locations.

- (iv) Differential brake hold-backs. This device is also comparatively cheap but as it relies on friction, is not as positive as the other devices listed above. This hold-back consists of a brake wheel, brake band and base-mounted cam. Movement in normal direction of travel actuates the cam through friction between the brake wheel and the band in such a manner that the band perimeter is increased, allowing free rotation. Movement in the opposite direction decreases the perimeter of the band, binding it against the brake wheel and preventing movement.

Differential band brakes are subject to failure from over-greasing, wear and icing. If used in dusty locations, they should always be covered. Such brakes require careful adjustment in the field.

- (v) Magnetic brake. This friction brake is normally actuated by a thruster or solenoid, and is always located on the high speed side of the reducer. It is generally used to supplement the action of more conventional types on high lift conveyors.

(d) Counterweight Reaction – Accelerating and Braking

Today's long centre, terrain following conveyors quite frequently, during acceleration or deceleration, generate forces which sometimes affect the amount of counterweight tension required in the system. If the counterweight is not sufficiently heavy to resist such forces, then it will move inwards and inevitably cause an accumulation of slack belt at some point of lower tension in the system. This in turn can cause severe spillage, damage to belt and/or idlers and in some cases, when the acceleration or deceleration phase is complete and the belt gives up its energy, the generation of longitudinal waves in the system, producing a phenomenon analogous to water hammer, which can severely damage terminal equipment such as pulleys, bearings, structures and even the belt itself.

The accelerating and decelerating force calculations are based on the simple assumption that the entire belt starts or stops at a uniform rate of acceleration or deceleration. This assumption is not completely accurate because of the elastic qualities of the belt itself. Textile belts tend to elongate more with the result that some sections of the belt reach either full speed or standstill much quicker than other sections. On the other hand, steel cord belts, with relatively high moduli of elasticity, and therefore inherently lower stretch characteristics, tend to behave in a manner much closer to the single mass assumption mentioned earlier. Depending on the magnitude of acceleration/deceleration forces, and the load condition of the system, the following general conditions will apply.

TABLE 8
RECOMMENDED DRIVE AND TAKE-UP LOCATIONS WITH COUNTERWEIGHT REACTION

| Conveyor Profile | Recommended Drive Location | Recommended Take-Up Location | Acceleration Effect | Deceleration Effect |
|---|----------------------------|--|--|---|
| 1. Horizontal | Head | Following drive | None | Slight counterweight lift. |
| 2. Incline | Head | As above – or at tail. | None | None |
| 3. Decline | Tail | At lowest tension point on return – usually head. | Possible slight counterweight lift. | None |
| 4. Multi-Slope (See note below) | Head | Following drive or at low tension point in system. | Little or none. | Demands attention – counterweight could lift and feed slack to low tension zones. |
| 5. Multi-Slope (See note below) | Tail | At head pulley or at low tension point in system. | Demands attention – counterweight could lift and feed slack to low tension zones. | Little or none. |
| 6. Regenerative decline with level section near head. | Tail | Following head pulley. | Demands attention – counterweight lifts and feeds slack to low tension zones on carrying side. | None |

NOTE: For conveyors with both incline and decline sections, the conveyor profile will dictate the optimum location of both drive and counterweight to keep system tension and power consumption to a minimum. For long centre, terrain following conveyors, multiple drives – i.e. at both head and tail – can prove economical by reducing system tension.

Where conditions such as envisaged in 4, 5 and 6 in Table 8 occur, it is customary to handle such problems with:

- (i) Very heavy single counterweight location.
- (ii) Dual counterweight locations.
- (iii) Tail end braking.
- (iv) Combinations of head/tail or head/intermediate or tail/intermediate drives.

In the case of (iv) it is suggested both the belt supplier and original equipment supplier be consulted to ensure that all aspects of the design are covered.

(e) Brake or Anti-Roll Back Devices

**TABLE 9
REQUIREMENT FOR BRAKE OR ANTI-ROLL BACK DEVICES**

| Conveyor Profile | Level | Incline | Decline |
|----------------------------|--|---|---|
| Brake Requirement | If coasting is excessive | Desirable | Essential |
| Brake Capacity | Deceleration force minus system friction | Incline load tension minus friction force | Deceleration force plus Incline load tension minus friction tension |
| Anti roll back Requirement | Nil | Essential | Nil |
| Anti roll back Capacity | Nil | Incline load tension minus friction of system | Nil |

(f) Accelerating and Braking Forces

The belt tension during acceleration or deceleration can be calculated for any critical point in the system (e.g. vertical curve). This tension is equal to the normal operating tension at that specific point in the system plus the additional tension caused by the forces of acceleration or deceleration. Each significantly different condition of loading should be investigated.

The three basic formulae used in such calculations are as follows:

$$F = ma \dots\dots\dots (3.33)$$

- where:
- m = Mass to be accelerated or decelerated (kg)
 - a = Acceleration or deceleration (m/s²)
 - F = Force or tension (N)

Where time required for acceleration or deceleration has to be calculated:

$$t = \frac{S}{a} \dots\dots\dots (3.34)$$

- where:
- S = Belt speed (m/s)
 - a = Average acceleration or deceleration (m/s²)
 - t = Time (secs.)

Where coasting is involved and distance is required:

$$d = \frac{at^2}{2} \dots\dots\dots (3.35)$$

a = Deceleration (m/s²)

t = Decelerating time (s)

d = Coasting or decelerating distance (m)

also

$$a = \frac{F}{m} \text{ where } \dots\dots\dots (3.36)$$

a, F and m are described earlier in this section.

When combinations of incline/decline become involved, e.g. on a terrain following conveyor where there could be multiple slopes involved, then careful consideration to acceleration and deceleration forces should be given.

APPLICATION OF FORCES

Accelerating and decelerating forces are distributed around conveyor systems in direct proportion to the mass involved. These masses are as follows:

(1) Conveyor Carrying Side

Belt mass + material mass + mass of carrying idler rotating parts.

Belt mass = B (kg/m), from Section 8

Material mass = $\frac{C}{3.6S}$ (kg/m)

Mass of trough idler parts = $\frac{W_t}{s_1}$ (kg/m)

(2) Conveyor Return Side

Belt mass + mass of return idler rotating parts

Belt mass = B (kg/m), from Section 8

Mass of return idler parts = $\frac{W_r}{s_1}$ (kg/m)

(3) Mass of Terminal Pulleys

On very long centre belts these are often neglected but these should be included. Such weights are readily available from the original equipment supplier.

From the foregoing, the total mass to be accelerated or decelerated can be calculated for any particular portion of the conveyor or loading condition by multiplying the masses per metre of the portion or loading condition being considered by the length of that portion.

Note that the sum of all masses on the carrying side and the sum of all masses on the return side must be used in each force calculation.

Typical average values for "a", the acceleration of a conveyor for different methods of starter control are given in Table 10.

TABLE 10
TYPICAL ACCELERATION VALUES "a" (m/s²)

| | |
|---|------------|
| Direct on line starters | 0.6 |
| Direct on line with traction type fluid couplings | 0.5 |
| Direct on line with "soft" starter technique | 0.35 - 0.4 |
| Direct on line with external reservoir traction type fluid couplings | 0.35 - 0.4 |
| Direct on line with scoop type fluid coupling torque acceleration controls | 0.3 |
| Direct on line with scoop type couplings – stepped motor control on eddy current clutch | 0.45 - 0.5 |
| Stepless second resistance | 0.25 - 0.3 |
| Drum controlled secondary resistance | 0.2 |

NOTE: A check should always be made by comparing the acceleration force calculated, with the permissible allowable for the belt, i.e. 150% of rated belt tension. If the assumed rate chosen exceeds the latter figure, then the choice of control must be changed or modified.

After calculating the forces involved for each particular load condition, the effect of those forces on belt tension can be determined arithmetically as follows:

- (a) Calculate the normal running forces in the conveyor for the loading condition under consideration, with the portion of those forces which relate to each section of the conveyor on the carrying and return side being calculated.
- (b) Calculate running tensions for other possible load conditions so that the counterweight for running conditions can be determined.
- (c) Calculate the accelerating and decelerating forces for each section of the conveyor using the mass "m" applicable to each of these sections.
- (d) When gravitational acceleration forces are to be considered for regenerative belts or gravitational deceleration forces for belts requiring power with power switched off, these forces are distributed around the conveyor in proportion to the masses in each section.
The gravitational acceleration or deceleration force for a particular load condition is equal to the effective tension, T_e , for that condition.
- (e) Add and/or subtract all the running and accelerating/decelerating forces calculated for the particular load condition being considered, to the counterweight already determined for the conveyor in accordance with the algebraic sign rules given below.
- (f) Check that there is no case where the minimum tension falls below T_{sag} . If this does occur, more counterweight is required which will affect the normal running tension and possibly the belt selection.

ALGEBRAIC SIGNS OF CONVEYOR FORCES

- (1) Empty friction (Formula 3.3, 3.4 and 3.5) and load friction (Formula 3.6) are always (+) in the direction of belt travel, and (-) against direction of belt travel.
- (2) Belt slope tension (Formula 3.8) is always (+) in uphill situations and (-) in downhill.
- (3) Load slope tension (Formula 3.7) is as given for (2) above.
- (4) Acceleration forces (externally applied) are always (+) in direction of belt travel and (-) against belt travel.

- (5) Gravitational forces to decelerate conveyor are always (-) in the direction of belt travel and (+) against direction of belt travel.
- (6) Gravitational forces to accelerate conveyor are always (+) in the direction of belt travel and (-) against direction of belt travel.

COASTING

Unless a conveyor is regenerative, it will coast to a gradual halt due to the inertia in the system when the drive power is shut off.

It may be necessary to calculate this natural coasting time (or distance) to determine if extra retardation in the form of a brake is required.

The three basic formulae described earlier under "Accelerating and Braking Forces" are again used in this respect, viz

$$a = \frac{F_i}{m} \dots\dots\dots (3.36)$$

$$t = \frac{S}{a} \dots\dots\dots (3.34)$$

$$d = \frac{at^2}{2} \dots\dots\dots (3.35)$$

where:

- a = Coasting deceleration (m/s²)
- F_i = Decelerating gravitational force (N)
- m = Mass to be decelerated (kg)
- t = Time to coast to halt (s)
- S = Normal operating belt speed (m/s)
- d = Distance to coast to half (m)

In the application of these formulae the terms (F_i) and (m) need further elaboration:

The decelerating gravitational force (F_i) is composed of two elements:

- (a) The effective tension (T_e) for the load condition being considered (i.e. conveyor empty or fully loaded for the whole length or perhaps for only one particular section of the conveyor), and
- (b) The Friction Losses of the Drive. As the speed reducer portion of the drive will have significantly greater friction losses than the motor portion, the latter may be neglected for simplicity. If the efficiency of the reduction unit is not known it may be assumed to be 97 or 98% (i.e. the friction losses may be assumed to be 2.5%). To convert these losses to units of force (newtons) calculate the following expression:

$$\frac{\text{Redn. Unit Power Rating (kW)} \times 1000 \times \text{No. of Redn Units} \times (\% \text{ Loss})}{\text{Belt Speed} \times 100} \dots\dots\dots (3.37)$$

Thus the total decelerating gravitational force (F_i) is then the sum of (T_e) and the value obtained from Formula 3.37 above, expressed in newtons.

The mass to be decelerated (m) is also composed of two elements:

- (a) The total mass of the material load, the belt and the rotating idler parts for the condition being considered:

$$\left(Q + \frac{C}{3.6S}\right) \times L \text{ (kg)} \dots\dots\dots (3.38)$$

- (b) The Equivalent Mass of the Drive System. To calculate this, the inertia (WK^2), expressed in kilogram metre squared, is substituted in the following expression:

$$\frac{(WK^2) \times (\text{Reduction Ratio})^2 \times \text{No. of Drives}}{(\text{Radius of Drive Pulley in metres})^2} \text{ (kg)} \dots\dots\dots (3.39)$$

Values of WK^2 for the Reduction Units, Motors and Couplings should be obtained from the equipment manufacturers.

From the above, values for (F_i) and (m) may now be substituted into the original basic formulae to determine (t) time taken and (d) distance required for the conveyor to coast to halt.

CHECK LIST FOR LARGE CONVEYOR SYSTEMS

Tensions:

- (a) Use tension diagram – compare with rated tensions.
- (b) Determine effect of accelerating and braking forces.

Pulleys:

- (a) Check diameters at all locations.
- (b) Check face width and lateral clearances at sides of pulleys.
- (c) Use of lagging.
- (d) Check use of crown on critical pulleys, e.g. head pulley.

Vertical curves:

- (a) Determine radii for concave and convex curves.
- (b) Check tripper design against curve required (empty and loaded).
- (c) Determine effect of accelerating or braking force on curve radius.

Take-up:

- (a) Movement required with respect to belt construction and method of joining – initial position of take-up governed by type of drive etc.
- (b) Effect of braking and accelerating forces on amount of weight – possible use of double take-up.
- (c) Check method of maintaining alignment of moving pulley.
- (d) Protection from spillage in vertical take-ups.

Idlers:

- (a) Spacing, relative to load and friction factors.
- (b) Tilting for self-aligning in uni-directional conveyors.
- (c) Necessity for transition idlers at head or tail.
- (d) Necessity for and location of self-aligning idlers.
- (e) Necessity for impact idlers.

Loading:

- (a) Determine percentage of volumetric capacity.
- (b) Impact considerations.
- (c) Check chute and skirt board design.

Brakes and anti-roll-backs:

- (a) The necessity of these.
- (b) Coasting or over-run of conveyors operating in sequence; inertia of motor and of reduction gearing should be included.

Motors:

- (a) Type required and starting programme.
- (b) Power split on two-motor drives.
- (c) Determine effect of fluid, centrifugal or electrical couplings.

Miscellaneous:

- (a) Spare belt recommendation.
- (b) Number and size of rolls for ease of handling at site or for entry to underground workings.
- (c) Field splicing and splice lengths.
- (d) Repair facilities.
- (e) Safety devices:
 - (i) Ploughs for cleaning return run.
 - (ii) Side travel limit switches.
 - (iii) Counterweight limit travel switches.
 - (iv) Plugged chute and full bin protection.
- (f) Consideration of standardisation programme for belting stocks.

4. Belt Carcass Selection

| | |
|--|--------------|
| Belt Construction Requirements | 4 - 1 |
| Considerations | 4 - 1 |
| Procedure | 4 - 2 |
| | |
| Table 1A Allowable Working Tensions – Standard constructions..... | 4 - 3 |
| Table 1B Allowable Working Tensions – CoalMaster series..... | 4 - 4 |
| Table 2A Load support table – Standard constructions..... | 4 - 5 |
| Table 2B Load support table – CoalMaster series..... | 4 - 6 |
| Table 3 Belt troughability –..... | 4 - 7 |

4. Belt Carcass Selection

BELT CONSTRUCTION REQUIREMENTS.

To select the optimum plied belt carcass, five properties must be considered:

- ◆ The belt width.
- ◆ The service conditions under which the belt will operate.
- ◆ The maximum operating tension (T_{max}) – both steady state condition and peak (see table 1).
- ◆ The minimum number of plies required to support the load (see tables 2).
- ◆ The maximum number of plies beyond which transverse flexibility is reduced and the troughing efficiency is affected. This varies with the belt width, trough angle and the idler roll arrangement (see table 3)

CONSIDERATIONS:

Operating conditions

The allowable working tensions shown on Table 1 that follow are applicable for reasonably well maintained conveyors operating with moderate impact, infrequent starts and good loading. Peak tension – on starting or braking, should not exceed 140% of the allowable working tension.

For more severe operating conditions, moderate maintenance, short time cycles, frequent DOL or loaded starts, poor loading or severe impact, hot materials handling etc., reduce the tabled figures by 15%. Tension on starting or braking should not exceed 150% of the resulting rated tension.

For severe service conditions, poor maintenance, very hot materials, chemically aggressive environment, severe impact and short time cycles etc., reduce the tabled figures by 30%. Tension on starting or braking should not exceed 160% of the resulting rated tension.

Safety factors

The working tensions shown on these tables are based on the application of a safety factor of 6.7:1 on the strength of the belt at the splice or fastened join. The safety factor is increased for more difficult operating conditions with further restrictions applying for starting and braking.

Starting and braking tensions

A check should always be made comparing the acceleration or braking tension with the allowable peak tension for the belt, ie. 140% of rated working tension. If the peak tension exceeds the latter figure, a stronger belt can be selected or the choice of control must be changed to reduce peak tension.

Mechanical fasteners

FENNER DUNLOP always recommend vulcanised splices for plain weave plied belting. Other constructions including the Crows Foot Weave, Double Weave and Solid Woven PVC can be successfully operated at close to vulcanised joint tensions for long periods of time whereas plain weave constructions generally operate at reduced tensions when fitted with mechanical fasteners

Recommended precautions including frequent inspection and monitoring, any Local Authority restrictions and greater than normal care should always be observed when using Mechanical Fasteners. Belt cleaners should only be fitted if specifically suited to operation with mechanical fasteners

If a conveyor belt is to be operated for any length of time with mechanical fasteners then the selected combination of belt and fastener should be statically tensile tested and a working tension of not more than 15% of that result. Table 1 lists *FENNER DUNLOP* recommendations for its common range of belts.

Troughability and load support

This table provides a guide to the maximum width of belt that will support the load when carrying material with the bulk density shown.

This table provides a guide to the minimum width of belt that will trough satisfactorily at the trough angle shown. The widths shown above are a guide only and experience may dictate the selection of a ply more or a ply less.

Some factors that may influence the choice are:

- ◆ Partially filled belt.
- ◆ Idler trough angle
- ◆ Convex or concave curve radius and idler pitch
- ◆ Lump size of material
- ◆ Installed pulley diameters

PROCEDURE:

Consider the possible belt constructions.

1. Calculate working tension needed for the both steady state and peak (accelerating or braking).

$$\text{Required Working Tension (kN/m)} = \frac{T_{\max} \text{ (kN)}}{\text{Belt width (m)}}$$

Where: T_{\max} = Peak or Steady State tension in conveyor (kN).

2. Considering operating conditions and starting and braking tensions and determine suitable belt constructions from tables 1A and 1B. Working tensions shown in tables 1A and 1B are applicable for reasonably well-maintained conveyors with moderate impact, infrequent starts and good loading and are reduced where operating conditions are less favourable - see discussion below
3. Consider special needs and the use of special fabrics such as Crow's foot or Double weaves.
4. Establish the various practical carcass/ ply number combinations to support the load for the conveyor working conditions under review - (Tables). Load support requirements may dictate that the selected belt is operating at a fraction of it's allowable working tension.
5. Check that the selected construction(s) are acceptable for troughing - (Table 3)
6. Check that the installed pulley diameters are adequate – (refer section 6)

The final selection should be checked with *APEX FENNER* since cost, availability and service criteria can be additional factors for consideration.

Table 1A – ALLOWABLE WORKING TENSION

Standard Constructions

(other than CoalMaster series)

| RECOMMENDED ALLOWABLE WORKING TENSION | | | | | | |
|---|-----------------|------------------------------|------------------------------|------------------------------|------------------------------|------------------------------|
| For reasonably well maintained conveyors with moderate impact, infrequent starts and good loading. | | | | | | |
| Number of plies | | <u>2</u> | <u>3</u> | <u>4</u> | <u>5</u> | <u>6</u> |
| PN 150 - 160 plain weave | Spliced | PN315 /2 24 kN/m | PN500 /3 50 kN/m | PN630 /4 72 kN/m | PN750 /5 90 kN/m | PN900 /6 112 kN/m |
| | Fastened | 27 kN/m | 40 kN/m | 53 kN/m | 66 kN/m | 79 kN/m |
| PN 200 - 220 plain weave | Spliced | PN400 /2 30 kN/m | PN630 /3 63 kN/m | PN800 /4 90 kN/m | PN1000 /5 120 kN/m | PN1200 /6 150 kN/m |
| | Fastened | 34 kN/m | 51 kN/m | 68 kN/m | 85 kN/m | 102 kN/m |
| PN 250 plain weave | Spliced | PN500 /2 37 kN/m | PN750 /3 75 kN/m | PN1000 /4 112 kN/m | PN1250 /5 150 kN/m | PN1500 /6 187 kN/m |
| | Fastened | See below | See below | See below | See below | See below |
| PN 300 - 315 plain weave | Spliced | PN630 /2 48 kN/m | PN900 /3 90 kN/m | PN1250 /4 140 kN/m | PN1500 /5 180 kN/m | PN1800 /6 225 kN/m |
| | Fastened | See below | See below | See below | See below | See below |
| PN 320 - 350 plain weave | Spliced | | PN1000 /3 100 kN/m | PN1400 /4 157 kN/m | PN1600 /5 192 kN/m | |
| | Fastened | | See below | See below | See below | |
| PN 360 - 400 plain weave | Spliced | PN800 /2 60 kN/m | PN1200 /3 120 kN/m | PN1500 /4 168 kN/m | PN1800 /5 216 kN/m | |
| | Fastened | See below | See below | See below | See below | |
| PN 315 - 375 Crow's foot weave | Spliced | PN750 /2 56 kN/m | PN1000 /3 100 kN/m | PN1250 /4 140 kN/m | PN1600 /5 192 kN/m | |
| | Fastened | 56 kN/m | 84 kN/m | 112 kN/m | 140 kN/m | |
| PN 360 - 400 Crow's foot weave | Spliced | PN800 /2 60 kN/m | PN1200 /3 120 kN/m | PN1500 /4 168 kN/m | PN1800 /5 216 kN/m | |
| | Fastened | 70 kN/m | 105 kN/m | 140 kN/m | 175 kN/m | |
| PN 450 - 500 Crow's foot weave | Spliced | | PN1500 /3 150 kN/m | PN1800 /4 202 kN/m | PN2250 /5 270 kN/m | |
| | Fastened | | See below | See below | See below | |
| PN 450 Double weave | Spliced | PN900 /2 67.5 kN/m | PN1350 /3 135 kN/m | | | |
| | Fastened | 90 kN/m | 135 kN/m | | | |

Not generally recommended for permanent use with mechanical fasteners, but may be used with fasteners either temporarily or permanently under certain conditions.

Table 1B – ALLOWABLE WORKING TENSION

CoalMaster series
(For underground coal mining)

| RECOMMENDED ALLOWABLE WORKING TENSION | | | | | |
|--|-----------------|---|---|---|---|
| For reasonably well maintained conveyors with moderate impact, infrequent starts and good loading. | | | | | |
| Number of plies | <u>2</u> | <u>3</u> | <u>4</u> | <u>5</u> | <u>6</u> |
| PN 150 - 160 plain weave Spliced Fastened | | | PN630 /4 72 kN/m 53 kN/m | PN800 /5 96 kN/m 66 kN/m | |
| PN 200 - 220 plain weave Spliced Fastened | | | PN800 /4 90 kN/m 68 kN/m | PN1000 /5 120 kN/m 85 kN/m | PN1200 /6 150 kN/m 102 kN/m |
| PN 250 plain weave Spliced Fastened | | | PN1000 /4 112 kN/m See below | PN1250 /5 150 kN/m See below | PN1500 /6 187 kN/m See below |
| PN 300 - 315 plain weave Spliced Fastened | | | PN1250 /4 140 kN/m See below | PN1500 /5 180 kN/m See below | |
| PN 320 - 350 plain weave Spliced Fastened | | | PN1400 /4 157 kN/m See below | PN1750 /5 210 kN/m See below | |
| PN 360 - 400 plain weave Spliced Fastened | | | PN1600 /4 180 kN/m See below | PN2000 /5 240 kN/m See below | |
| PN 315 - 375 Crow's foot weave Spliced Fastened | | PN1120 /3 100 kN/m 90 kN/m | PN1400 /4 157 kN/m 115 kN/m | PN1600 /5 192 kN/m 140 kN/m | |
| PN 360 - 400 Crow's foot weave Spliced Fastened | | PN1200 /3 120 kN/m 105 kN/m | PN1600 /4 180 kN/m 140 kN/m | PN1875 /5 225 kN/m 175 kN/m | |
| PN 450 - 500 Crow's foot weave Spliced Fastened | | PN1500 /3 150 kN/m See below | PN2000 /4 225 kN/m See below | PN2500 /5 300 kN/m See below | |
| PN 450 Double weave Spliced Fastened | | PN1350 /3 135 kN/m 135 kN/m | | | |

Not generally recommended for permanent use with mechanical fasteners, but may be used with fasteners either temporarily or permanently under certain conditions.

Table 2A - LOAD SUPPORT

Plain Weave Fabrics

(with standard thickness skim)

| <u>MAXIMUM WIDTH TO SUPPORT THE LOAD</u> | | | | | |
|---|---|--|--|--|---|
| For conventional troughed conveyors | | | | | |
| <u>Number of plies</u> | <u>2</u> | <u>3</u> | <u>4</u> | <u>5</u> | <u>6</u> |
| PN 150 - 160 plain weave 800 kg/m³ Load 1200 kg/m³ Bulk density: 1800 kg/m³ 2600 kg/m³ | PN315 /2 900 mm 700 mm 600 mm - | PN500 /3 1100 mm 1000 mm 800 mm 500 mm | PN630 /4 1600 mm 1500 mm 1300 mm 1000 mm | PN750 /5 2100 mm 1900 mm 1700 mm 1500 mm | PN900 /6 2500 mm 2400 mm 2200 mm 1900 mm |
| PN 200 - 220 plain weave 800 kg/m³ Load 1200 kg/m³ Bulk density: 1800 kg/m³ 2600 kg/m³ | PN400 /2 1100 mm 1000 mm 800 mm 500 mm | PN630 /3 1300 mm 1200 mm 1000 mm 800 mm | PN800 /4 1800 mm 1700 mm 1500 mm 1300 mm | PN1000 /5 2400 mm 2300 mm 2100 mm 1800 mm | PN1200 /6 - - - 2300 mm |
| PN 250 plain weave 800 kg/m³ Load 1200 kg/m³ Bulk density: 1800 kg/m³ 2600 kg/m³ | PN500 /2 1200 mm 1100 mm 900 mm 700 mm | PN750 /3 1500 mm 1400 mm 1200 mm 1100 mm | PN1000 /4 2100 mm 2000 mm 1800 mm 1600 mm | PN1250 /5 - mm - mm 2500 mm 2200 mm | PN1500 /6 - - - - |
| PN 300 - 315 plain weave 800 kg/m³ Load 1200 kg/m³ Bulk density: 1800 kg/m³ 2600 kg/m³ | PN630 /2 1400 mm 1300 mm 1100 mm 800 mm | PN900 /3 1800 mm 1600 mm 1500 mm 1200 mm | PN1250 /4 - mm 2500 mm 2300 mm 2100 mm | PN1500 /5 - - - - | PN1800 /6 - - - - |
| PN 320 - 350 plain weave 800 kg/m³ Load 1200 kg/m³ Bulk density: 1800 kg/m³ 2600 kg/m³ | | PN1000 /3 2000 mm 1800 mm 1600 mm 1400 mm | PN1400 /4 - - 2400 mm 2200 mm | PN1600 /5 - - - - | |
| PN 360 - 400 plain weave 800 kg/m³ Load 1200 kg/m³ Bulk density: 1800 kg/m³ 2600 kg/m³ | PN800 /2 1600 mm 1500 mm 1300 mm 1000 mm | PN1200 /3 2100 mm 2000 mm 1800 mm 1600 mm | PN1500 /4 2400 mm - - - | PN1800 /5 - - - - | |

Table 2B - LOAD SUPPORT

Special Weave Fabrics

(with standard thickness skim)

| <u>MAXIMUM WIDTH TO SUPPORT THE LOAD</u> | | | | | |
|--|-----------------|-----------------|-----------------|-----------------|-----------------|
| For conventional troughed conveyors | | | | | |
| <u>Number of plies</u> | <u>2</u> | <u>3</u> | <u>4</u> | <u>5</u> | <u>6</u> |
| PN 315 - 375 Crow's foot 800 kg/m³ weave 1200 kg/m³ Bulk density: 1800 kg/m³ 2600 kg/m³ | PN750/2 | PN1000/3 | PN1250/4 | PN1600/5 | |
| | 1600 mm | 2100 mm | - | - | |
| | 1500 mm | 2000 mm | - | - | |
| | 1300 mm | 1800 mm | - | - | |
| | 1000 mm | 1600 mm | 2400 mm | - | |
| PN 360 - 400 Crow's foot 800 kg/m³ weave 1200 kg/m³ Bulk density: 1800 kg/m³ 2600 kg/m³ | PN800/2 | PN1200/3 | PN1500/4 | PN1800/5 | |
| | 1700 mm | 2400 mm | - | - | |
| | 1600 mm | 2200 mm | - | - | |
| | 1400 mm | 2000 mm | - | - | |
| | 1200 mm | 1800 mm | - | - | |
| PN 450 - 500 Crow's foot 800 kg/m³ weave 1200 kg/m³ Bulk density: 1800 kg/m³ 2600 kg/m³ | | PN1500/3 | PN1800/4 | PN2250/5 | |
| | | - | - | - | |
| | | - | - | - | |
| | | 2400 mm | - | - | |
| | | 2200 mm | - | - | |
| PN 450 Double weave 800 kg/m³ 1200 kg/m³ Bulk density: 1800 kg/m³ 2600 kg/m³ | PN900/2 | PN1350/3 | | | |
| | 1900 mm | - | | | |
| | 1800 mm | - | | | |
| | 1600 mm | - | | | |
| | 1300 mm | - | | | |

Table 3 – TROUGHABILITY

Plain Weave Fabrics

(with standard thickness skim)

| MINIMUM WIDTH TO TROUGH THE BELT (For conventional troughed conveyors) | | | | | | |
|--|---|--|---|---|---|--|
| Number of plies | 2 | 3 | 4 | 5 | 6 | |
| PN 150 - 160 plain weave 20 to 30° 30 to 40° up to 45° | PN315 /2 - - 400 mm | PN500 /3 400 mm 450 mm 500 mm | PN630 /4 450 mm 500 mm 600 mm | PN750 /5 500 mm 600 mm 650 mm | PN900 /6 600 mm 750 mm 800 mm | |
| PN 200 - 220 plain weave 20 to 30° 30 to 40° up to 45° | PN400 /2 mm 450 mm 500 mm | PN630 /3 450 mm 500 mm 650 mm | PN800 /4 500 mm 650 mm 800 mm | PN1000 /5 650 mm 750 mm 900 mm | PN1200 /6 800 mm 900 mm 1050 mm | |
| PN 250 plain weave 20 to 30° 30 to 40° up to 45° | PN500 /2 400 mm 450 mm 600 mm | PN750 /3 450 mm 600 mm 750 mm | PN1000 /4 650 mm 800 mm 900 mm | PN1250 /5 800 mm 900 mm 1050 mm | PN1500 /6 900 mm 1000 mm 1350 mm | |
| PN 300 - 315 plain weave 20 to 30° 30 to 40° up to 45° | PN630 /2 400 mm 500 mm 600 mm | PN900 /3 600 mm 650 mm 800 mm | PN1250 /4 750 mm 800 mm 1000 mm | PN1500 /5 800 mm 900 mm 1050 mm | PN1800 /6 1000 mm 1050 mm 1200 mm | |
| PN 320 - 350 plain weave 20 to 30° 30 to 40° up to 45° | | PN1000 /3 600 mm 750 mm 800 mm | PN1400 /4 750 mm 900 mm 1000 mm | PN1600 /5 900 mm 1050 mm 1200 mm | | |
| PN 360 - 400 plain weave 20 to 30° 30 to 40° up to 45° | PN800 /2 500 mm 600 mm 650 mm | PN1200 /3 650 mm 750 mm 900 mm | PN1500 /4 800 mm 900 mm 1050 mm | PN1800 /5 1050 mm 1200 mm 1400 mm | | |
| PN 315 - 375 Crow's foot weave 20 to 30° 30 to 40° up to 45° | PN750 /2 500 mm 600 mm 750 mm | PN1000 /3 650 mm 750 mm 900 mm | PN1250 /4 750 mm 900 mm 1050 mm | PN1600 /5 900 mm 1050 mm 1350 mm | | |
| PN 360 - 400 Crow's foot weave 20 to 30° 30 to 40° up to 45° | PN800 /2 500 mm 650 mm 750 mm | PN1200 /3 650 mm 750 mm 900 mm | PN1500 /4 800 mm 900 mm 1050 mm | PN1800 /5 1050 mm 1200 mm 1500 mm | | |
| PN 450 - 500 Crow's foot weave 20 to 30° 30 to 40° up to 45° | | PN1500 /3 900 mm 1050 mm 1200 mm | PN1800 /4 1050 mm 1200 mm 1400 mm | PN2250 /5 1200 mm 1400 mm 1600 mm | | |
| PN 450 Double weave 20 to 30° 30 to 40° up to 45° | PN900 /2 650 mm 750 mm 900 mm | PN1350 /3 900 mm 1000 mm 1200 mm | | | | |

5. Cover Gauges and Qualities

| | |
|-----------------------------------|--------------|
| Considerations..... | 5 - 1 |
| Selection..... | 5 - 1 |
| Pulley side cover..... | 5 - 1 |
| | |
| Table 1 Top Cover Thickness | 5 – 2 |

5. Cover gauges and qualities

CONSIDERATIONS

There are a number of factors that must be taken into account when selecting the belt grade or cover material, such as:

- ◆ Fire resistance or anti-static properties
- ◆ Resistance to oils or chemicals
- ◆ Temperature of the operating environment or conveyed material
- ◆ Resistance to ageing, weathering and ozone.
- ◆ The type of material being conveyed
- ◆ The lump size and shape of the material being conveyed
- ◆ The mix of lumps and fines in the material
- ◆ The abrasiveness of the material
- ◆ The method of loading the belt
- ◆ The fall height of material to the belt
- ◆ The cycle time of the conveyor for a single revolution of the belt
- ◆ Performance or experience in a similar application
- ◆ For replacement belts – the performance of previous belts on the same installation
- ◆ Availability and cost

SELECTION

Previous experience will always be the best guide to the optimum selection of both the type and thickness of belt cover, however if this information is not available as will be the case for new installations, the following steps should be followed.

- ◆ From table 1 – 2 select the most suitable cover types of cover or belt grades for the application. In some cases statutory requirements or the operating conditions will limit selections to one or two possibilities.
- ◆ Calculate the time cycle of the conveyor = $\frac{2 \times L}{S}$

Where: L = conveyor centres (m)
S = belt speed (m/s)

- ◆ Use table 1 as a guide to select the appropriate thickness of top cover. Consideration should be given to the applicable properties of the cover in making this selection.

For difficult applications such as belt feeders, or impact belts, heavier covers may be required.

PULLEY SIDE COVER

As a guide, pulley side cover should generally be not less than 1/4 of carry side cover for covers up to 9mm and about 1/3 of carry cover thickness for covers heavier than 9mm. Operating conditions can dictate that heavier pulley side covers are required.

For long centre, long time cycle conveyors, pulley side cover can be up to 1/2 of carry side cover.

**TABLE 1
BELT COVER THICKNESS**

| Time cycle seconds $\frac{(2 \times L)}{S}$ Cycle time for complete belt revolution. | <u>Lightly abrasive materials</u> | | | | | <u>Moderately abrasive materials</u> | | | | | <u>Heavily abrasive materials</u> | | | | | <u>Extremely abrasive materials</u> | | | | |
|--|---|-----|-----|------|-------|---|-----|------|------|-------|---|-----|------|-------|-------|---|------|------|-------|-------|
| | Lump size (mm) | | | | | Lump size (mm) | | | | | Lump size (mm) | | | | | Lump size (mm) | | | | |
| | 10 | 50 | 125 | 200 | 300 | 10 | 50 | 125 | 200 | 300 | 10 | 50 | 125 | 200 | 300 | 10 | 50 | 125 | 200 | 300 |
| 15 seconds | 1-2 | 3-5 | 6-7 | 8-10 | 10-12 | 1-2 | 4-5 | 7-10 | 9-12 | 11-15 | 2-4 | 4-7 | 7-10 | 10-15 | 12-19 | 3-6 | 4-10 | 8-15 | 10-19 | 13-23 |
| 30 seconds | 1-2 | 3-4 | 5-6 | 6-8 | 8-10 | 1-2 | 3-4 | 5-8 | 7-10 | 9-12 | 2-3 | 3-6 | 6-10 | 8-12 | 10-15 | 2-5 | 4-8 | 6-12 | 8-15 | 10-18 |
| 60 seconds | 1-2 | 2-3 | 4-5 | 5-6 | 7-8 | 1-2 | 3-4 | 5-6 | 6-8 | 7-10 | 1-3 | 3-5 | 5-8 | 6-10 | 8-13 | 2-4 | 3-6 | 5-10 | 7-13 | 9-15 |
| 120 seconds | 1-2 | 2-3 | 3-4 | 5-6 | 6-7 | 1-2 | 2-3 | 4-6 | 5-7 | 6-9 | 1-2 | 2-4 | 4-7 | 6-9 | 7-11 | 2-4 | 3-6 | 5-7 | 6-11 | 8-13 |
| 180 seconds and over | 1-2 | 1-2 | 3-4 | 4-5 | 5-6 | 1-2 | 2-3 | 4-5 | 5-6 | 6-8 | 1-2 | 2-4 | 4-6 | 5-8 | 6-10 | 2-3 | 2-5 | 4-8 | 5-10 | 7-12 |
| Typical materials | Wood chips - bituminous coal - grains - round river gravel etc. | | | | | Basalt - sand - anthracite coal - crushed gravel etc. | | | | | Limestone - ores - phosphate - slag - cement clinker etc. | | | | | Glass cullet - granite - quartz ores etc. | | | | |

6. Pulley Diameters

Parallel face pulleys..... 6 - 1

Crown face pulleys..... 6 - 2

Pulley face width..... 6 - 2

Table 1A Standard constructions
 – operating at over 60% of allowable working tension 6 - 3

Table 1B CoalMaster series
 – operating at over 60% of allowable working tension 6 - 4

Table 2A Standard constructions
 – operating at 30 - 60% of allowable working tension 6 - 5

Table 2B CoalMaster series
 – operating at 30 - 60% of allowable working tension 6 - 6

6. Pulley diameters

The minimum pulley diameter recommended for a particular belt depends upon three factors:

- Carcass Thickness – The wire rope diameter in the case of Steel Cord belts.
– The overall thickness of all plies plus the rubber skins between plies in the case of Ply Type belts.
– The overall thickness of the thick woven fabric separating the top and bottom covers in the case of Solid-woven belts.
- Operating Tension – The relationship of the operating tension of the belt at the particular pulley to the belt's Allowable Working Tension.
- Carcass modulus – The relationship between elongation of the carcass and the resulting stress.

Whatever the carcass type, Steel Cord, Ply Type or Solid Woven, when the belt is bent around a small radius, tension stresses are developed in the outer fibres while compression stresses are built up in the inner fibres. At a given tension, if the radius is too small the elastic limit of the outer fibres may be exceeded and fracture, and at the same time, the compression of the inner fibres may cause severe crinkling and eventual ply separation.

Since the elastic properties of the rubber or PVC cover material is so much greater than the carcass material, the cover thickness of the belting is not a factor in determining minimum pulley size, and may be ignored.

The tables of recommended pulley diameters in the *FENNER DUNLOP* handbook for Ply Type belting are based on the three classes of pulleys defined in ISO 3684. viz.;

- Type "A" – High tension / tight side pulleys (T1) e.g. head, drive, tripper and shuttle pulleys
- Type "B" – Low tension or slack side pulleys (T2) such as tail and take up pulleys
- Type "C" – Low tension snub or bend pulleys with wrap angle of less than 30 degrees

Two sets of Pulley Diameter tables follow:

- For belts operating at over 60% of allowable working tension
Table 1 A - for standard belt constructions
Table 1 B – for *CoalMaster* series belts
- For belts operating at 30 – 60% of allowable working tension
Table 2 A - for standard belt constructions
Table 2 B – for *CoalMaster* series belts

For belts operating at less than 30% of the allowable working tension, the diameter of Type "A" pulleys can be reduced to the same as Type "B".

PARALLEL FACE PULLEYS

With just a few special exceptions, all pulleys used with modern high strength, high modulus fabric belts should be parallel face types. It is absolutely mandatory that all pulleys used in conveyors fitted with Steel Cord belting be parallel face type. One notable exception to this rule is in the case of Bucket Elevators which, lacking any other means of tracking the belt centrally, may benefit from Crown Faced Pulleys.

CROWN FACE PULLEYS

A Crown Faced pulley can have the effect of centering the tracking of the belt, but only in the case where there is a long unsupported length of belt leading into the pulley, as the belt must be able to bend longitudinally along its centreline to benefit from the crown. High modulus Ply Type belts have very little ability to bend longitudinally and Steel Cord belts have virtually no ability at all. Solid Woven belts are not quite so rigid but still need an unsupported distance of something like 4 to 6 times the belt width to be able to react.

Apart from not serving much purpose in troughed conveyor systems, Crowned pulleys can seriously damage the belt by severely overstressing the carcass in the centre of the belt, particularly in the case of Steel Cord belts.

The few special cases where Crowned pulleys are useful include, Bucket Elevators, the Take-up pulley in long gravity Take-up arrangements and for some short centre - wide belt, reversing conveyors. In cases like this where there are no supporting idlers to train the belt, some benefit may be obtained from the installation of Crowned pulleys.

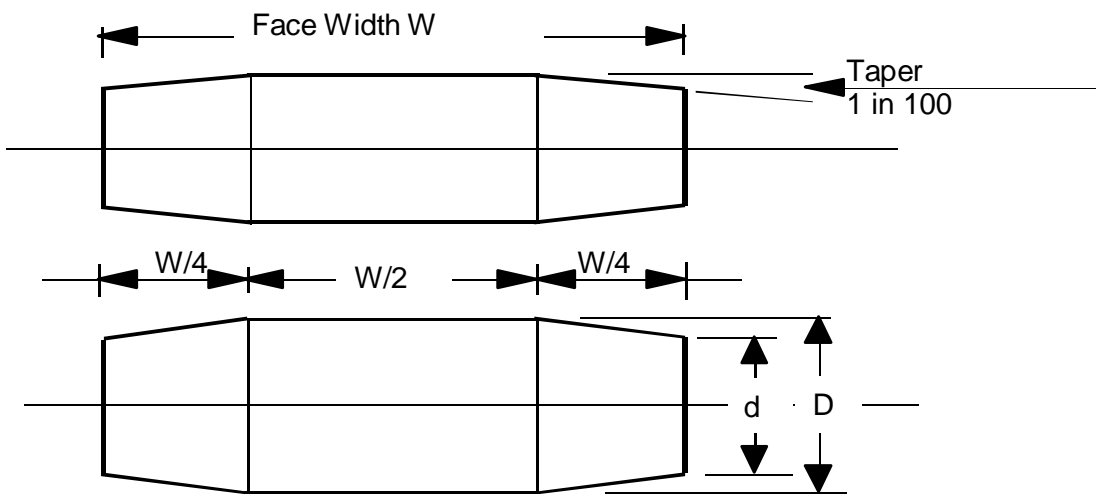

It is fairly common practice to crown a pulley by machining a taper of 1 in 100 from each pulley edge towards the centre over a distance of 1/4 pulley face. It is more correct to relate the amount of pulley crown to the pulley diameter, not to its face width. Viz.; $d = D - 0.008 \times D$

PULLEY FACE WIDTH

As all belts tend to wander a bit in operation, the overall face width of the pulleys should exceed the belt width by the following minimum amounts, if serious edge damage is to be avoided;

- Belts up to 650mm wide 100mm
- Belts 750 to 1400mm wide 150mm
- Belts over 1400mm wide 200mm

For conveyors built on unstable ground, as in underground coal mines and very long overland conveyors, the above allowances should be increased by 50mm.

TABLE 1A
STANDARD CONSTRUCTIONS
(other than CoalMaster series)

| RECOMMENDED MINIMUM PULLEY DIAMETERS | | | | | | |
|--|----------|---------------------------|-----------------------------|-----------------------------|-----------------------------|-----------------------------|
| For belts operating at over 60% of maximum allowable working tension | | | | | | |
| Number of plies | | 2 | 3 | 4 | 5 | 6 |
| PN 150 - 160 plain weave | Type "A" | PN315 /2 315 mm | PN500 /3 400 mm | PN630 /4 560 mm | PN750 /5 710 mm | PN900 /6 800 mm |
| | Type "B" | 250 mm | 315 mm | 450 mm | 560 mm | 630 mm |
| | Type "C" | 200 mm | 250 mm | 360 mm | 450 mm | 500 mm |
| PN 200 - 220 plain weave | Type "A" | PN400 /2 400 mm | PN630 /3 450 mm | PN800 /4 630 mm | PN1000 /5 800 mm | PN1200 /6 900 mm |
| | Type "B" | 315 mm | 360 mm | 500 mm | 630 mm | 710 mm |
| | Type "C" | 250 mm | 280 mm | 400 mm | 500 mm | 560 mm |
| PN 250 plain weave | Type "A" | PN500 /2 450 mm | PN750 /3 500 mm | PN1000 /4 710 mm | PN1250 /5 900 mm | PN1500 /6 1120 mm |
| | Type "B" | 360 mm | 400 mm | 560 mm | 710 mm | 900 mm |
| | Type "C" | 280 mm | 315 mm | 450 mm | 560 mm | 710 mm |
| PN 300 - 315 plain weave | Type "A" | PN630 /2 500 mm | PN900 /3 560 mm | PN1250 /4 800 mm | PN1500 /5 1120 mm | PN1800 /6 1400 mm |
| | Type "B" | 400 mm | 450 mm | 630 mm | 900 mm | 1120 mm |
| | Type "C" | 315 mm | 360 mm | 500 mm | 710 mm | 900 mm |
| PN 320 - 350 plain weave | Type "A" | | PN1000 /3 630 mm | PN1400 /4 900 mm | PN1600 /5 1120 mm | |
| | Type "B" | | 500 mm | 710 mm | 900 mm | |
| | Type "C" | | 400 mm | 560 mm | 710 mm | |
| PN 360 - 400 plain weave | Type "A" | PN800 /2 560 mm | PN1200 /3 710 mm | PN1500 /4 1000 mm | PN1800 /5 1250 mm | |
| | Type "B" | 450 mm | 560 mm | 800 mm | 1000 mm | |
| | Type "C" | 360 mm | 450 mm | 630 mm | 800 mm | |
| PN 315 - 375 Crow's foot weave | Type "A" | PN750 /2 560 mm | PN1000 /3 710 mm | PN1250 /4 1000 mm | PN1600 /5 1250 mm | |
| | Type "B" | 450 mm | 560 mm | 800 mm | 1000 mm | |
| | Type "C" | 360 mm | 450 mm | 630 mm | 800 mm | |
| PN 360 - 400 Crow's foot weave | Type "A" | PN800 /2 560 mm | PN1200 /3 800 mm | PN1500 /4 1000 mm | PN1800 /5 1250 mm | |
| | Type "B" | 450 mm | 630 mm | 800 mm | 1000 mm | |
| | Type "C" | 360 mm | 500 mm | 630 mm | 800 mm | |
| PN 450 - 500 Crow's foot weave | Type "A" | | PN1500 /3 900 mm | PN1800 /4 1250 mm | PN2250 /5 1600 mm | |
| | Type "B" | | 710 mm | 1000 mm | 1250 mm | |
| | Type "C" | | 560 mm | 800 mm | 1000 mm | |
| PN 450 Double weave | Type "A" | PN900 /2 630 mm | PN1350 /3 1000 mm | | | |
| | Type "B" | 500 mm | 800 mm | | | |
| | Type "C" | 400 mm | 630 mm | | | |

TABLE 1B
COALMASTER SERIES
(For underground coal mining)

| RECOMMENDED MINIMUM PULLEY DIAMETERS | | | | | | |
|--|----------|----------|-----------------------------|-----------------------------|-----------------------------|-----------------------------|
| For belts operating at over 60% of maximum allowable working tension | | | | | | |
| Number of plies | | 2 | 3 | 4 | 5 | 6 |
| PN 150 - 160 plain weave | Type "A" | | | PN630 /4 500 mm | PN800 /5 710 mm | |
| | Type "B" | | | 400 mm | 560 mm | |
| | Type "C" | | | 315 mm | 450 mm | |
| PN 200 - 220 plain weave | Type "A" | | | PN800 /4 630 mm | PN1000 /5 800 mm | PN1200 /6 1000 mm |
| | Type "B" | | | 500 mm | 630 mm | 800 mm |
| | Type "C" | | | 400 mm | 500 mm | 630 mm |
| PN 250 plain weave | Type "A" | | | PN1000 /4 800 mm | PN1250 /5 1000 mm | PN1500 /6 1250 mm |
| | Type "B" | | | 630 mm | 800 mm | 1000 mm |
| | Type "C" | | | 500 mm | 630 mm | 800 mm |
| PN 300 - 315 plain weave | Type "A" | | | PN1250 /4 800 mm | PN1500 /5 1000 mm | |
| | Type "B" | | | 630 mm | 800 mm | |
| | Type "C" | | | 500 mm | 630 mm | |
| PN 320 - 350 plain weave | Type "A" | | | PN1400 /4 900 mm | PN1750 /5 1120 mm | |
| | Type "B" | | | 710 mm | 900 mm | |
| | Type "C" | | | 560 mm | 710 mm | |
| PN 360 - 400 plain weave | Type "A" | | | PN1600 /4 1000 mm | PN2000 /5 1250 mm | |
| | Type "B" | | | 800 mm | 1000 mm | |
| | Type "C" | | | 630 mm | 800 mm | |
| PN 315 - 375 Crow's foot weave | Type "A" | | PN1120 /3 800 mm | PN1400 /4 1000 mm | PN1600 /5 1250 mm | |
| | Type "B" | | 630 mm | 800 mm | 1000 mm | |
| | Type "C" | | 500 mm | 630 mm | 800 mm | |
| PN 360 - 400 Crow's foot weave | Type "A" | | PN1200 /3 900 mm | PN1600 /4 1000 mm | PN1875 /5 1250 mm | |
| | Type "B" | | 710 mm | 800 mm | 1000 mm | |
| | Type "C" | | 560 mm | 630 mm | 800 mm | |
| PN 450 - 500 Crow's foot weave | Type "A" | | PN1500 /3 1120 mm | PN2000 /4 1250 mm | PN2500 /5 1600 mm | |
| | Type "B" | | 900 mm | 1000 mm | 1250 mm | |
| | Type "C" | | 710 mm | 800 mm | 1000 mm | |
| PN 450 Double weave | Type "A" | | PN1350 /3 1000 mm | | | |
| | Type "B" | | 800 mm | | | |
| | Type "C" | | 630 mm | | | |

TABLE 2A
STANDARD CONSTRUCTIONS
(other than CoalMaster series)

| RECOMMENDED MINIMUM PULLEY DIAMETERS | | | | | | |
|---|----------|---------------------------|----------------------------|-----------------------------|-----------------------------|-----------------------------|
| For belts operating at over 30% up to 60% of maximum allowable working tension. <i>(for belts operating at less than 30% of allowable working tension, diameters shown for type "B" can be used for type "A" pulleys)</i> | | | | | | |
| Number of plies | | 2 | 3 | 4 | 5 | 6 |
| PN 150 - 160 plain weave | Type "A" | PN315 /2 250 mm | PN500 /3 315 mm | PN630 /4 450 mm | PN750 /5 560 mm | PN900 /6 630 mm |
| | Type "B" | 200 mm | 250 mm | 360 mm | 450 mm | 500 mm |
| | Type "C" | 160 mm | 200 mm | 280 mm | 360 mm | 400 mm |
| PN 200 - 220 plain weave | Type "A" | PN400 /2 315 mm | PN630 /3 360 mm | PN800 /4 500 mm | PN1000 /5 630 mm | PN1200 /6 710 mm |
| | Type "B" | 250 mm | 280 mm | 400 mm | 500 mm | 560 mm |
| | Type "C" | 200 mm | 225 mm | 315 mm | 400 mm | 450 mm |
| PN 250 plain weave | Type "A" | PN500 /2 360 mm | PN750 /3 400 mm | PN1000 /4 560 mm | PN1250 /5 710 mm | PN1500 /6 900 mm |
| | Type "B" | 280 mm | 315 mm | 450 mm | 560 mm | 710 mm |
| | Type "C" | 225 mm | 250 mm | 360 mm | 450 mm | 560 mm |
| PN 300 - 315 plain weave | Type "A" | PN630 /2 400 mm | PN900 /3 450 mm | PN1250 /4 630 mm | PN1500 /5 900 mm | PN1800 /6 1120 mm |
| | Type "B" | 315 mm | 360 mm | 500 mm | 710 mm | 900 mm |
| | Type "C" | 250 mm | 280 mm | 400 mm | 560 mm | 710 mm |
| PN 320 - 350 plain weave | Type "A" | | PN1000 /3 500 mm | PN1400 /4 710 mm | PN1600 /5 900 mm | |
| | Type "B" | | 400 mm | 560 mm | 710 mm | |
| | Type "C" | | 315 mm | 450 mm | 560 mm | |
| PN 360 - 400 plain weave | Type "A" | PN800 /2 450 mm | PN1200 /3 560 mm | PN1500 /4 800 mm | PN1800 /5 1000 mm | |
| | Type "B" | 360 mm | 450 mm | 630 mm | 800 mm | |
| | Type "C" | 280 mm | 360 mm | 500 mm | 630 mm | |
| PN 315 - 375 Crow's foot weave | Type "A" | PN750 /2 450 mm | PN1000 /3 560 mm | PN1250 /4 800 mm | PN1600 /5 1000 mm | |
| | Type "B" | 360 mm | 450 mm | 630 mm | 800 mm | |
| | Type "C" | 280 mm | 360 mm | 500 mm | 630 mm | |
| PN 360 - 400 Crow's foot weave | Type "A" | PN800 /2 450 mm | PN1200 /3 630 mm | PN1500 /4 800 mm | PN1800 /5 1000 mm | |
| | Type "B" | 360 mm | 500 mm | 630 mm | 800 mm | |
| | Type "C" | 280 mm | 400 mm | 500 mm | 630 mm | |
| PN 450 - 500 Crow's foot weave | Type "A" | | PN1500 /3 710 mm | PN1800 /4 1000 mm | PN2250 /5 1250 mm | |
| | Type "B" | | 560 mm | 800 mm | 1000 mm | |
| | Type "C" | | 450 mm | 630 mm | 800 mm | |
| PN 450 Double weave | Type "A" | PN900 /2 500 mm | PN1350 /3 800 mm | | | |
| | Type "B" | 400 mm | 630 mm | | | |
| | Type "C" | 315 mm | 500 mm | | | |

TABLE 2B
COALMASTER SERIES
(For underground coal mining)

| RECOMMENDED MINIMUM PULLEY DIAMETERS | | | | | | |
|---|----------------------------------|-----------------|--|---|--|---|
| For belts operating at over 30% up to 60% of maximum allowable working tension. <i>(for belts operating at less than 30% of allowable working tension, diameters shown for type "B" can be used for type "A" pulleys)</i> | | | | | | |
| Number of plies | | <u>2</u> | <u>3</u> | <u>4</u> | <u>5</u> | <u>6</u> |
| PN 150 - 160 plain weave | Type "A" Type "B" Type "C" | | | PN630 /4 400 mm 315 mm 250 mm | PN800 /5 560 mm 450 mm 360 mm | |
| PN 200 - 220 plain weave | Type "A" Type "B" Type "C" | | | PN800 /4 500 mm 400 mm 315 mm | PN1000 /5 630 mm 500 mm 400 mm | PN1200 /6 800 mm 630 mm 500 mm |
| PN 250 plain weave | Type "A" Type "B" Type "C" | | | PN1000 /4 630 mm 500 mm 400 mm | PN1250 /5 800 mm 630 mm 500 mm | PN1500 /6 1000 mm 800 mm 630 mm |
| PN 300 - 315 plain weave | Type "A" Type "B" Type "C" | | | PN1250 /4 630 mm 500 mm 400 mm | PN1500 /5 800 mm 630 mm 500 mm | |
| PN 320 - 350 plain weave | Type "A" Type "B" Type "C" | | | PN1400 /4 710 mm 560 mm 450 mm | PN1750 /5 900 mm 710 mm 560 mm | |
| PN 360 - 400 plain weave | Type "A" Type "B" Type "C" | | | PN1600 /4 800 mm 630 mm 500 mm | PN2000 /5 1000 mm 800 mm 630 mm | |
| PN 315 - 375 Crow's foot weave | Type "A" Type "B" Type "C" | | PN1120 /3 630 mm 500 mm 400 mm | PN1400 /4 800 mm 630 mm 500 mm | PN1600 /5 1000 mm 800 mm 630 mm | |
| PN 360 - 400 Crow's foot weave | Type "A" Type "B" Type "C" | | PN1200 /3 710 mm 560 mm 450 mm | PN1600 /4 800 mm 630 mm 500 mm | PN1875 /5 1000 mm 800 mm 630 mm | |
| PN 450 - 500 Crow's foot weave | Type "A" Type "B" Type "C" | | PN1500 /3 900 mm 710 mm 630 mm | PN2000 /4 1000 mm 800 mm 630 mm | PN2500 /5 1250 mm 1000 mm 800 mm | |
| PN 450 Double weave | Type "A" Type "B" Type "C" | | PN1350 /3 800 mm 630 mm 500 mm | | | |

7. Design Considerations

| | |
|---|--------------|
| Multiple Slope and Vertical Curve Conveyors | 7 - 1 |
| Terminal Troughing Idler Arrangements | 7 - 4 |
| Transitions | 7 - 4 |
| Take – Up Arrangements | 7 - 5 |
| | |
| Table 1 Average Elastic Modulus ‘E’ | 7 - 3 |
| Table 2 Transition Distances for Head Pulleys | 7 - 4 |
| Table 3 Transition Distances for Tail End Loading Points | 7 - 5 |
| Table 4 Gravity Take – Up Travel | 7 - 6 |

7. Design considerations

MULTIPLE SLOPE AND VERTICAL CURVE CONVEYORS

Conveyors with grade variations, and particularly decline regenerative systems with concave vertical curves, require special consideration. In their design a thorough analysis is necessary, particularly at points of low tension. The effect of varying load conditions as well as acceleration and deceleration must be considered carefully.

Determination of vertical curves

(1) Concave vertical curves

(a) Selection of radius to prevent belt lifting off idlers

(i) Squirrel-cage motor, D.O.L. start:

$$R = \frac{* (2.0 \text{ to } 2.5) \times T_i}{B \times 9.81 \times 10^{-3}} \quad (\text{m}) \dots\dots\dots (7.1)$$

(ii) Squirrel-cage motor, D.O.L. start with traction type coupling or centrifugal clutch:

$$R = \frac{* (1.7 \text{ to } 2.0) \times T_i}{B \times 9.81 \times 10^{-3}} \quad (\text{m}) \dots\dots\dots (7.2)$$

(iii) Squirrel-cage motor, D.O.L. start with scoop type fluid coupling or eddy-current clutch; slip-ring motor, electrically controlled start:

$$R = \frac{* (1.3 \text{ to } 1.6) \times T_i}{B \times 9.81 \times 10^{-3}} \quad (\text{m}) \dots\dots\dots (7.3)$$

where:

R = Radius of curvature (m).

T_i = Maximum operating tension (total belt width) at the point of tangent intersection (kN).

B = Belt mass (kg/m).

* = The difference and range in these values apply to the motor and starter characteristics, and should be varied according to the type of control chosen for the installation under consideration.

(iv) On decline regenerative conveyors even with the best of control, the very minimum radius at the foot of a steep decline should always be calculated from the following:

$$R = \frac{1.8 T_i}{B \times 9.81 \times 10^{-3}} \quad (\text{m}) \dots\dots\dots (7.4)$$

Consideration should then be given to closer idler spacing at locations immediately following such steep declines.

(b) Selection of radius to prevent belt edge tension from dropping below zero and causing possible buckling:

The formula to give a radius of curvature which will result in zero edge tension in the belt is:

$$R = \frac{\text{Sin } \theta \times W \times E \times N}{4.5 (T_{C1} - 0)} \quad (\text{m}) \dots\dots\dots (7.5)$$

where:

W = Belt width (m).

*E = Elastic modulus (kN/m/ply) from Table 1 of this section.

*N = Number of plies.

T_{C1} = Maximum operating tension at point of tangent intersection (kN/m).

θ = Carrying idler troughing angle.

*For Steel Cord belts, N = 1 and E has units of kilonewtons per metre.

As positive tension is preferable in the belt edges, the value of that tension should be substituted in the denominator of the formula. As a general rule, 4.4 kN is used as the desired minimum tension. With that minimum tension value, the formula will read:

$$R = \frac{\sin \theta \times W \times E \times N}{4.5 (T_{C1} - 4.4)} \quad (\text{m}) \dots\dots\dots (7.5a)$$

Other minimum tension values could be substituted to suit particular installations.

- Note:
- (i) In calculations to determine the radius of concave curves to prevent the belt lifting off the idlers, design tonnage figures should be used.
 - (ii) In calculations to determine the radius of concave curves below which negative edge tensions (and hence edge buckling) will occur, actual tonnage rates should be used, particularly when design tonnage rates are significantly above the rates which will occur in practice.

(2) Convex vertical curves

(a) Selection of radius to keep belt edge tension within acceptable limits:

$$R = \frac{\sin \theta \times W \times E \times N}{4.5 (T_a - T_{C2})} \quad (\text{m}) \dots\dots\dots (7.6)$$

(b) Selection of radius to keep tension at centre of belt above zero and thereby prevent possible buckling:

The formula to give zero tension in the centre of the belt is:

$$R = \frac{\sin \theta \times W \times E \times N}{9 (T_{C2} - 0)} \quad (\text{m}) \dots\dots\dots (7.7)$$

where:

θ = Troughing angle of carrying idlers.

W = Belt width (m).

*E = Elastic modulus (kN/m/ply) from Table 1 of this section.

*N = Number of plies.

T_a = Recommended allowable working tension for the belt reinforcement used, (kN/m) from Table 1 of Section 4.

T_{C2} = Maximum operating tension at point of tangent intersection (kN/m).

*For steel cord belts, N = 1 and E has units of kilonewtons per metre.

As a general rule, positive tension should be provided, and 4.4 kN is usually used as the desired minimum tension, in which case the formula becomes:

$$R = \frac{\sin \theta \times W \times E \times N}{9 (T_{C2} - 4.4)} \quad (\text{m}) \dots\dots\dots (7.7a)$$

- Note:
- (i) In calculations to determine radius of convex curves to keep edge tension within acceptable limits, design tonnage rates should be used.
 - (ii) In calculations to determine the radius of convex curves below which negative tension at the centre of the belt will occur, actual tonnage rates should be used particularly when design tonnage rates are significantly above rates which will occur in practice.

The equipment supplier should always check radial force component caused by the belt on the idlers in the transition area. If the curve is calculated by means of either (a) or (b) above, the general result is that method (a) determines the radius in most cases. For idler load limitations, check ratings etc. with the idler supplier.

(3) Horizontal curves

In recent years horizontal curves have been used in long centre terrain - following conveyors as a means of eliminating transfer points and so reducing costs and increasing efficiency. No attempt is made here to detail all the variables involved in designing such curves, except to say that the largest possible radius should always be used and the minimum allowable radius is 900 x belt width in metres.

Idlers in the transition area should be somewhat wider than usual and not less than 35' inclination on the carrying side and 15' inclination on the return. In some cases normal trough idlers are also used on the return run.

In addition to forward tilting of the carry idlers in the direction of belt travel, it is also helpful to tilt the idler frames to provide a reverse camber around the curve. That is, starting at the beginning of the curve, packing should be provided under the end of the idler frames at the inside of the curve. The thickness of this packing should be progressive from say 1 mm at the beginning of the curve to about 75 mm at the centre of the curve, then progressively decreasing to 1 mm again at the end of the curve. This reverse camber effect assists in preventing the belt climbing the idlers towards the centre of the curve.

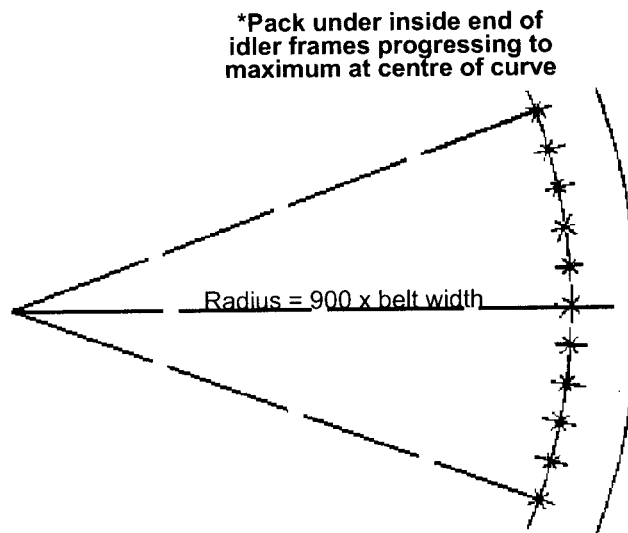

Plan of typical horizontal curve

**TABLE 1
AVERAGE ELASTIC MODULUS "E"**

| PLAIN WEAVE FABRICS | | SPECIAL WEAVE FABRICS | |
|---------------------|---------------|--------------------------|---------------|
| PN150 – 160 | 2100 kN/m/ply | Crow's foot weave | |
| PN200 – 220 | 2300 kN/m/ply | PN315 – 350 | 3400 kN/m/ply |
| PN250 | 2800 kN/m/ply | PN360 – 400 | 2900 kN/m/ply |
| PN300 – 315 | 3000 kN/m/ply | PN450 – 500 | 4500 kN/m/ply |
| PN320 – 350 | 3000 kN/m/ply | Double weave | |
| PN360 – 400 | 2800 kN/m/ply | PN450 | 4000 kN/m/ply |

TERMINAL TROUGHING IDLER ARRANGEMENTS

It is recommended that the first or last standard troughing idler over which the belt passes under high tension as it leaves or approaches a terminal pulley, be mounted on a level which will average the belt edge stresses.

If the terminal pulley is set so that a tangent line from its rim is above the top of the centre roll by an amount equal to half the height of the troughing idler, the belt edge stresses are minimised and the optimum level of the last standard troughing idler is obtained. (See Fig. 2)

Where the belt is not operating at high tension and very large lumps are carried, the best position for the terminal pulley with respect to the last standard troughing idler is to have the pulley rim set so that the tangent line from it will be tangent to the top of the centre roll. (See Fig. 3). This position increases belt edge stress but lessens the chances of belt injury due to the impinging effect of large lumps against the pulley.

At tail end loading points with low to moderate belt tensions, this position is also used, and ensures that the belt cannot lift at the loading point and interfere with the skirting.

Always locate first the standard troughing idler prior to the loading chute, and incorporate intermediate troughing angle idler sets between the terminal pulleys and the steep-angle-troughing idler run.

TRANSITIONS

Suggested minimum belt transition distances (terminal troughing idlers to terminal pulleys)

FIG. 2

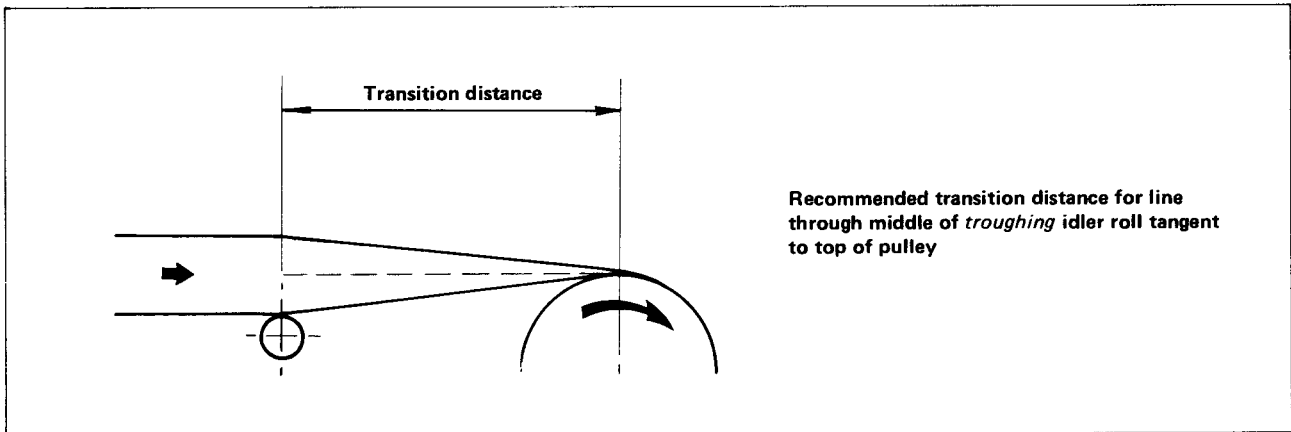

TABLE 2

TRANSITION DISTANCES FOR HEAD PULLEYS – generally high to moderate tension

| % of allowable working tension | All fabric belts | | | | Steel cord belts | | | |
|--------------------------------|------------------|------|------|------|------------------|------|------|------|
| | Troughing angle | | | | Troughing angle | | | |
| | 20° | 30° | 35° | 45° | 20° | 30° | 35° | 45° |
| 91 – 100 | 0.9W | 1.4W | 1.6W | 1.9W | 2.0W | 3.2W | 3.4W | 4.0W |
| 76 – 90 | 0.8W | 1.3W | 1.4W | 1.8W | 1.6W | 2.7W | 2.8W | 3.2W |
| 50 – 75 | 0.7W | 1.2W | 1.3W | 1.6W | 1.2W | 2.5W | 2.6W | 3.0W |
| Less than 50 | 0.5W | 1.0W | 1.0W | 1.3W | 1.1W | 1.8W | 1.8W | 2.4W |

W = belt width in metres

FIG. 3

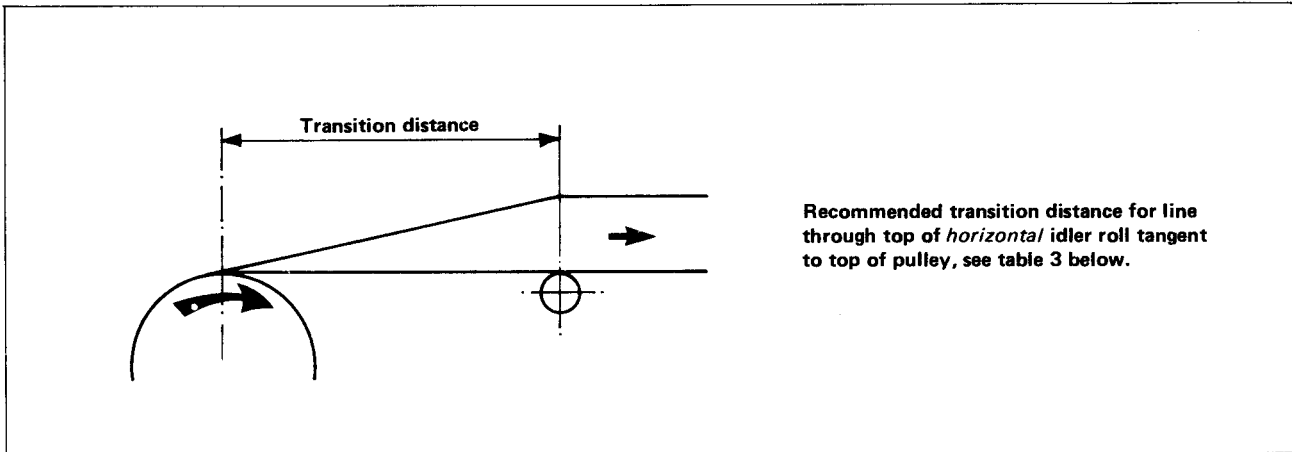

TABLE 3
TRANSITION DISTANCES FOR TAIL END LOADING POINTS –
generally low to moderate tension
(also low tension head drive pulleys and large product lumps)

| % of allowable working tension | All fabric belts | | | | Steel cord belts | | | |
|--------------------------------|------------------|------|------|------|------------------|------|------|------|
| | Troughing angle | | | | Troughing angle | | | |
| | 20° | 30° | 35° | 45° | 20° | 30° | 35° | 45° |
| 91 – 100 | 1.8W | 3.0W | 3.2W | 4.0W | 4.0W | 6.6W | 6.8W | 8.0W |
| 76 – 90 | 1.6W | 3.0W | 3.0W | 3.8W | 3.2W | 5.2W | 5.4W | 6.6W |
| 50 – 75 | 1.2W | 2.7W | 2.8W | 3.5W | 2.6W | 5.0W | 5.2W | 5.8W |
| Less than 50 | 1.0W | 2.0W | 2.0W | 2.8W | 2.4W | 3.6W | 3.8W | 4.0W |

W = belt width in metres

TAKE-UP ARRANGEMENTS

Gravity take-ups – vulcanised splices. The take up travel requirements shown in Table 4 are applicable to belts operating at between 75% and 100% of the allowable working tension, and with starting tension limited to 150% of allowable working tension.

For belts operating at between 50% and 75% of the allowable working tension, the travel distances shown in Table 4 can be reduced by 25%, whilst the travel distance for belts operating at less than 50% of the allowable tension can be reduced by 50%.

Belts operating at high temperatures or under very wet conditions may require take up travel distances up to 50% longer than shown in Table 4.

For long to very long centre belts using low elongation Kuralon/Nylon and Polyester/Nylon carcass constructions, take-up travel can be progressively reduced as necessary to suit available space, down to as little as 0.25–0.5% of centre to centre length of conveyor (contact Apex Belting for recommendations). Provided accelerating and braking forces are kept to reasonable limits, belt stretch after some initial elongation becomes minimal.

Screw take-ups – vulcanised splices and all fastened joints. Travels can generally be reduced to approximately half those shown in Table 4.

However, for take-ups with vulcanised splices, always provide sufficient travel to permit re-splice of the belt if required without having to insert a new piece.

TABLE 4
GRAVITY TAKE-UP TRAVEL

(A) FABRIC BELTING

| Centre to centre length of conveyor (metres) | Travel in percent of conveyor centre distance (minimum) | | |
|--|---|-----|------------|
| | CC | NN | KN, PN, PP |
| Up to 30 | 2.0 | 4.0 | 2.0 |
| 31 – 60 | 1.9 | 3.5 | 1.7 |
| 61 – 180 | 1.8 | 3.4 | 1.6 |
| 181 – 300 | 1.8 | 3.3 | 1.5 |
| Over 300 | 1.8 | 3.3 | 1.3 |

NOTE: A practical minimum take-up travel should not be less than 1 metre

Initial location of take-ups. To eliminate all belt sag on the installation of a new belt, pull the belt ends together against the installed counterweight. Take-ups can be initially located as follows:

- (1) For Nylon/Nylon carcass belts, hard against the inner stop;
- (2) For all other synthetic fabric carcass constructions, from hard against the inner stop to 20% of total travel from inner stop;
- (3) With Cotton/Cotton carcasses, from 20% up to 50% travel from inner stop for operating conditions ranging from dry to wet.

(B) STEEL CORD BELTING

The high modulus characteristic of the steel wire ropes used in the construction of steel cord conveyor belting results in extremely low elongation. This high strength, low stretch characteristic gives steel cord belting a tremendous advantage over fabric belts on long single flight systems.

With proper tensioning of the belt during the closing splice operation, take-up as low as 0.25% of conveyor centre distance is possible. Where the belt is designed to operate at tensions up to 100% rated tension a take-up travel of 0.5% is normally recommended.

8. General Data

- Belt Mass and thickness..... 8 - 1**
- Shipping dimensions and roll sizes..... 8 - 1**
- Length of belt on a roll..... 8 - 2**
- Belt transport guidelines..... 8 - 3**
- Belt installation and reel sequencing..... 8 - 4**

- Table 1 Belt carcass mass and thickness
– standard constructions..... 8 - 5
- Table 2 Belt carcass mass and thickness
– CoalMaster series..... 8 - 6
- Table 3 Belt carcass and cover mass factors..... 8 - 7

8. General Data

BELT MASS AND THICKNESS

On the following pages are three tables:

Table 1

Belt Carcass Mass and Thickness for Standard Belt Constructions
(other than *CoalMaster* belting for underground coal mining)

Table 2

Belt Carcass Mass and Thickness for *CoalMaster* Belting
(for underground coal mining)

Table 3

Carcass Mass Factor and Cover Mass Factor

To calculate Belt Mass

- Look up Belt Carcass Mass (kg/m^2) from either table 1 - Standard Belt Constructions or table 2 - *CoalMaster* Belting as applicable.
- To obtain the actual Belt Carcass Mass, multiply this by the Belt Carcass Mass factor from table 3.
- To obtain the mass of the belt covers, add together the top and bottom cover thickness and multiply this by the Belt Cover Mass factor, also from table 3.
- Add together the mass of the Belt Carcass and Covers for the belt mass per square metre (kg/m^2) and multiply by the belt width (in metres) for the belt mass per metre run (kg/m).

To obtain belt thickness

- Look up Belt Carcass Thickness (mm) from either table 1 - Standard Belt Constructions or table 2 - *CoalMaster* Belting as applicable.
- Add to this the thickness of both the top and bottom covers.

SHIPPING DIMENSIONS AND ROLL SIZES

Roll diameter

Roll diameter for belts can be determined from figure 1 below. The diameters shown are for a belt wrapped on a 600mm-diameter centre. For belts supplied on enclosed drums, an additional 0.15m should be added for clearance and slats where fitted.

Alternatively the diameter can be calculated from the following formula:

$$D = \sqrt{d^2 + (0.001273 \times L \times G)}$$

Where D = Overall diameter (m)
d = core diameter (m)
L = Belt length (m)
G = Belt thickness (mm)

Shipping dimensions

Add 50mm to belt width for clearance on belts supplied on cores.
 For belts supplied on enclosed drums:
 - Add 300mm to belt width
 - Add 150mm to belt diameter

Figure 1. Belt roll diameter

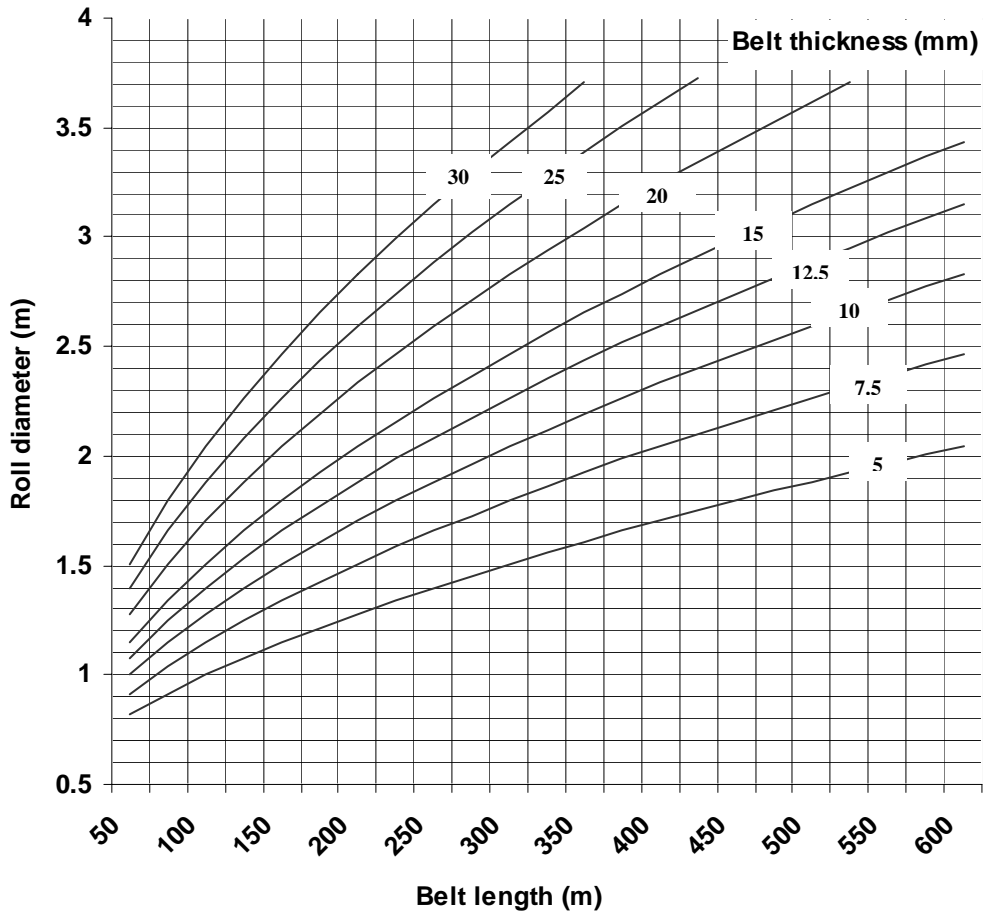

LENGTH OF BELT ON A ROLL

The length of belt on a roll may be determined using either of the following formula:

$$L = (d + (D - d) / 2) \times \pi \times N$$

or

$$L = H \times N \times \pi$$

Where D = outside diameter of the roll (m)
 d = diameter of the roll centre (m)
 N = the number of wraps of the belt
 H = height of the centre core (m)
 $\pi = 3.1416$

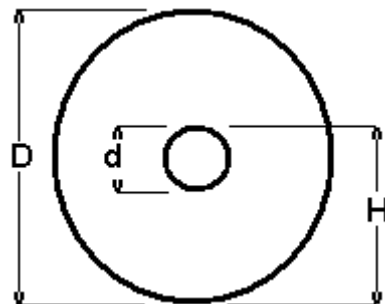

BELT TRANSPORT GUIDELINES

Road freight

| <u>Trailer type</u> | <u>Maximum roll diameter</u> | <u>Load weight</u> |
|---------------------|------------------------------|--------------------|
| Tray | 2.75m | 20 – 22 tonne |
| Drop-deck | 3.20m | 20 tonne |
| Low loader | 3.8m * | 1 roll |

* may vary with loader height and State regulations

Sea freight

| <u>Container type</u> | <u>Maximum roll diameter</u> | <u>Load weight</u> |
|-----------------------|------------------------------|--------------------|
| 20 ft. or 40 ft. * | 2.29m | 18.3 tonne |
| Heavy duty | 2.29m | 21.3 tonne |

*Container internal dimensions (nominal):
20ft – 2.29m high x 2.35m wide x 5.93m long
40ft – 2.29m high x 2.35m wide x 12.0m long

BELT INSTALLATION AND REEL SEQUENCING

Installation

Belt Installation and Splicing is a specialist service, and Fenner Dunlop recommend only using qualified and competent personnel to install and splice belting.

Fenner Dunlop can provide installation services using qualified Belt Splicers, supported by experienced Field Leaders and Engineers.

Belt Installation Sequence

Where multiple reels of belt are required Fenner Dunlop recommend installing belting in the sequence of manufacture and with each reel oriented in the same direction as it is installed onto the conveyor.

Reel Orientation can be confirmed using the detail contained in the Branding. Typical branding will be presented in the format **AS1333 ST4000 AS-A/Z-LRR 14 7 K1234/5 21 APEX 3**. The final digit is the Station Number. To ensure consistent Reel Orientation the Station Numbers must all either increase or decrease along the length of the belt when installed.

Alternatively, Reel Orientation can be confirmed by ensuring that the Branding on the Carry Cover of the Belt is all on the same side of the conveyor.

The sequence of manufacture is identified by the Reel Number. The Reel Number is branded into the Carry Cover of the Belt and marked on the Reel. Reels are typically numbered in the format **K1234/5**, where:

- “K” is the Manufacturing Location,
- “1234” is the Batch Number, and
- “5” is the Reel Number.

If the installation methodology requires reels to be installed out of sequence, discuss requirements prior to order placement.

The recommendation to sequence and align the Reels of Belt during installation is considered best practice and is intended to eliminate the potential for unstable belt tracking that may result from slight variations in geometry of the belt.

In the case of belting manufactured Side-By-Side, the same methodology can be applied, with the Reels numbered and Branded to reflect the appropriate installation sequence.

Splicing

Fenner Dunlop Splicing Materials and Splice Kits are recommended. These Splicing Materials have been tested and developed to ensure compatibility with the Belt.

Splice Patterns are designed for each application, with key splice and curing details defined in the Fenner Dunlop Splice Print. Splice Prints are included in the Splice Kit.

The quality of the finished splice is dependent on the skills and systems used by the Installer. Splices should only be performed by Trained Personnel in accordance with documented Splicing and Quality Management procedures.

TABLE 1
STANDARD CONSTRUCTIONS
(other than CoalMaster series)

| BELT CARCASS MASS AND THICKNESS | | | | | |
|---|--|--|---|---|---|
| Number of plies | 2 | 3 | 4 | 5 | 6 |
| PN 150 - 160 plain weave | PN315 /2 3.7 kg/m ² 2.7 mm | PN500 /3 4.4 kg/m ² 3.3 mm | PN630 /4 5.8 kg/m ² 4.6 mm | PN750 /5 7.3 kg/m ² 5.9 mm | PN900 /6 8.8 kg/m ² 7.1 mm |
| PN 200 - 220 plain weave | PN400 /2 4.4 kg/m ² 3.3 mm | PN630 /3 5.1 kg/m ² 3.9 mm | PN800 /4 6.8 kg/m ² 5.3 mm | PN1000 /5 8.5 kg/m ² 6.8 mm | PN1200 /6 10.2 kg/m ² 8.2 mm |
| PN 250 plain weave | PN500 /2 4.4 kg/m ² 3.3 mm | PN750 /3 5.8 kg/m ² 4.5 mm | PN1000 /4 7.7 kg/m ² 6.1 mm | PN1250 /5 9.6 kg/m ² 7.8 mm | PN1500 /6 11.5 kg/m ² 9.5 mm |
| PN 300 - 315 plain weave | PN630 /2 5.4 kg/m ² 4.1 mm | PN900 /3 6.8 kg/m ² 5.4 mm | PN1250 /4 9.1 kg/m ² 7.4 mm | PN1500 /5 11.4 kg/m ² 9.4 mm | PN1800 /6 14.6 kg/m ² 11.8 mm |
| PN 320 - 350 plain weave | | PN1000 /3 7.2 kg/m ² 5.6 mm | PN1400 /4 9.7 kg/m ² 7.7 mm | PN1600 /5 12.1 kg/m ² 9.8 mm | |
| PN 360 - 400 plain weave | PN800 /2 6.0 kg/m ² 4.7 mm | PN1200 /3 7.7 kg/m ² 6.1 mm | PN1500 /4 10.4 kg/m ² 8.4 mm | PN1800 /5 13.9 kg/m ² 11.3 mm | |
| PN 315 - 375 Crow's foot weave | PN750 /2 6.0 kg/m ² 4.7 mm | PN1000 /3 7.7 kg/m ² 6.1 mm | PN1250 /4 10.3 kg/m ² 8.4 mm | PN1600 /5 13.0 kg/m ² 10.7 mm | |
| PN 360 - 400 Crow's foot weave | PN800 /2 6.4 kg/m ² 5.0 mm | PN1200 /3 8.3 kg/m ² 6.7 mm | PN1500 /4 11.1 kg/m ² 9.1 mm | PN1800 /5 14.0 kg/m ² 11.6 mm | |
| PN 450 - 500 Crow's foot weave | | PN1500 /3 9.5 kg/m ² 7.7 mm | PN1800 /4 12.7 kg/m ² 10.5 mm | PN2250 /5 15.9 kg/m ² 13.3 mm | |
| PN 450 Double weave | PN900 /2 7.0 kg/m ² 5.5 mm | PN1350 /3 11.0 kg/m ² 9.0 mm | | | |

TABLE 2
COALMASTER SERIES
(For underground coal mining)

| <u>BELT CARCASS MASS AND THICKNESS</u> | | | | | |
|---|-----------------|---|--|--|--|
| Add 1.4 kg/m ² for each millimetre of cover | | | | | |
| <u>Number of plies</u> | <u>2</u> | <u>3</u> | <u>4</u> | <u>5</u> | <u>6</u> |
| PN 150 - 160 plain weave Mass Thickness | | | PN630 /4 7.8 kg/m ² 4.6 mm | PN800 /5 9.6 kg/m ² 5.9 mm | |
| PN 200 - 220 plain weave Mass Thickness | | | PN800 /4 9.5 kg/m ² 5.8 mm | PN1000 /5 11.9 kg/m ² 7.4 mm | PN1200 /6 14.2 kg/m ² 9.0 mm |
| PN 250 plain weave Mass Thickness | | | PN1000 /4 11.1 kg/m ² 6.9 mm | PN1250 /5 13.9 kg/m ² 8.8 mm | PN1500 /6 16.6 kg/m ² 10.7 mm |
| PN 300 - 315 plain weave Mass Thickness | | | PN1250 /4 11.7 kg/m ² 7.4 mm | PN1500 /5 14.0 kg/m ² 9.0 mm | |
| PN 320 - 350 plain weave Mass Thickness | | | PN1400 /4 12.2 kg/m ² 7.7 mm | PN1750 /5 15.3 kg/m ² 9.8 mm | |
| PN 360 - 400 plain weave Mass Thickness | | | PN1600 /4 13.3 kg/m ² 8.6 mm | PN2000 /5 16.5 kg/m ² 10.9 mm | |
| PN 315 - 375 Crow's foot weave Mass Thickness | | PN1120 /3 9.8 kg/m ² 6.1 mm | PN1400 /4 13.0 kg/m ² 8.4 mm | PN1600 /5 16.2 kg/m ² 10.7 mm | |
| PN 360 - 400 Crow's foot weave Mass Thickness | | PN1200 /3 10.5 kg/m ² 6.7 mm | PN1600 /4 13.9 kg/m ² 9.1 mm | PN1875 /5 17.3 kg/m ² 11.6 mm | |
| PN 450 - 500 Crow's foot weave Mass Thickness | | PN1500 /3 12.1 kg/m ² 8.0 mm | PN2000 /4 16.0 kg/m ² 10.8 mm | PN2500 /5 20.0 kg/m ² 13.8 mm | |
| PN 450 Double weave Mass Thickness | | PN1350 /3 14.1 kg/m ² 9.0 mm | | | |

**TABLE 3
BELT CARCASS AND
COVER MASS FACTORS**

| BELT GRADE | CARCASS MASS FACTOR | COVER MASS FACTOR |
|------------|---------------------|-------------------|
|------------|---------------------|-------------------|

MINING QUARRYING and GENERAL SERVICE BELTS

| | | |
|--------------|---|------|
| Grade M | - | 1.11 |
| Grade N | - | 1.11 |
| Grade A | - | 1.11 |
| Super M | - | 1.10 |
| Grade MA | - | 1.10 |
| XCG | - | 1.14 |
| QuarryMaster | - | 1.11 |

HEAT RESISTANT GRADES

| | | |
|-----------------|------|------|
| CRHR | - | 1.15 |
| EPT-GP | - | 1.05 |
| EPT-Super | - | 1.05 |
| HRNR | - | 1.10 |
| Hi-Temp Nitrile | 1.05 | 1.16 |

OIL and CHEMICAL RESISTANT GRADES

| | | |
|--------------|------|------|
| Nitrile | 1.05 | 1.16 |
| ORS Neoprene | 1.2 | 1.40 |
| PVC Nitrile | 1.05 | 1.19 |
| SOR | - | 1.14 |
| K, SOR | - | 1.24 |
| EPT-GP | - | 1.05 |

FIRE RESISTANT and ANTISTATIC BELTS

| | | |
|-------------------------|-----------------------------------|------|
| Grade S,D & grade S | <i>Use table 2 CoalMaster</i> | 1.40 |
| Grade D,E,F & grade E,F | 1.2 | 1.40 |
| Grade K,D | 1.2 | 1.40 |
| Grade K,L & grade K | 1.1 | 1.28 |
| Grade K, SOR | - | 1.24 |
| Grade E | - | 1.11 |

9. Solid Woven Belting

| | |
|--|---------------|
| Belt construction | 9 - 1 |
| Belt and cover thickness | 9 - 2 |
| Operating temperature range | 9 - 2 |
| Operating factor of safety | 9 - 2 |
| Safety | 9 - 2 |
| | |
| Table 1 Belt Designations | 11 - 3 |

9. Solid Woven belting

BELT CONSTRUCTION

Fenaplast conveyor belting consists of three main components: -

- ◆ Textile Solid Woven Carcass
- ◆ PVC Impregnation
- ◆ Cover Material

THE TEXTILE CARCASS

The solid-woven carcass is typically woven with nylon or polyester load bearing warp fibres and nylon or nylon/cotton weft. Synthetic binder yarns follow a complex pattern to give the carcass its solid-woven properties. Various combinations of synthetic and natural fibres are chosen, together with the fabric design to meet the requirements of impact resistance, belt elongation, flexibility for troughing and small diameter pulleys, load support and fastener retention. The patented Fenaplast PVC impregnation method also renders the carcass impervious to attack from moisture, dirt, chemicals, bacteria, and oils. Cotton pile warp yarns may be included for improved impact resistance and special edge reinforcement can be included where these are particular problems. The Fenaplast carcass design facility enables users to choose the properties of a custom-built belt.

All Fenaplast belts have a solid woven carcass where all layers of yarn are mechanically interlocked during the weaving process and bound together by a self binding warp yarn interweave, thus making subsequent delamination impossible. High tenacity continuous filament synthetic yarns are used for the warp (ie length direction), such yarns also provide most of the necessary strength in the weft (transverse/width) direction.

PVC IMPREGNATION

After weaving the roll of carcass is vacuum impregnated with PVC plastisol containing a careful blend of polymer, plasticisers, stabilisers, fire retardants, and special additives, with special attention being given to viscosity control in order to ensure full impregnation of the woven structure.

Whilst the textile elements fix many of the belts properties such as tensile strength and elongation in service, the properties of the plastisol are equally important, and it's formulation will influence not only the fire performance properties but also operational factors such as troughability and the ability to hold fasteners.

COVER MATERIAL

PVC Covers

PVC Covers to meet numerous fire resistance specifications or for other properties such as resistance to oils, chemicals, fertiliser etc., are generally available up to 3mm thick per side. They can also be compounded to give improved abrasion resistance or coefficients of friction.

Rubber Covers

Rubber covers to a specified safety standard may be applied on one or both sides of a PVC impregnation parent belt up to a maximum of 6mm + 2mm, dependent on belt width, tensile and construction. SR wear-resistant nitrile rubber covers are also available, single or double sided, up to 6mm + 2mm maximum, dependent on belt construction.

BELT AND COVER THICKNESS

When considering cover thickness the user should be aware of the thick, high textile content of Fenaplast and the special solid-woven carcass properties. Consequently thinner covers may generally be chosen than normal with rubber, plied belting; the Fenaplast carcass being more substantial and providing the necessary load support and impact resistance.

OPERATING TEMPERATURE RANGE

Above 90°C PVC softens and the belt properties change, therefore Fenaplast is not recommended for conveying materials above this temperature. Standard Fenaplast can be used in cold climates at minus 15°C and special cover compounds are available for operation down to minus 40°C. Cold weather details should be supplied to ensure a belt with suitable coefficient and flexibility characteristics is supplied.

BELT JOINTS

Vulcanised Spliced Joint

Fenaplast belting can be vulcanised using the Fenaplast Finger Splice method on a variety of polymeric materials with conventional rectangular presses. Vulcanised joints achieve strengths close to original strength of the parent belt.

Mechanical Fasteners

The unique PVC impregnated Solid Woven Fenaplast carcass provides superior belt clip holding capabilities, improving joint efficiency and increased service life

Note! Mechanical fasteners are not recommended for long term trunk or short centered high trip conveyor installations

SAFETY

Fenaplast is used extensively in underground coal mines and as such it exhibits excellent Fire Resistant, Anti-Static properties.

Australia - manufactured to AS1332 and tested to AS1334, which meets and exceeds all of the requirements of AS 4606-2000.

TABLE 1**BELT DESIGNATIONS**

| Belt Designation | Minimum warp strength kN/m | Minimum weft strength kN/m | Rated tension kN/m | Nominal belt thickness mm | Nominal belt weight kg/m ² | Minimum recommended pulley diameters | | |
|------------------|-------------------------------|-------------------------------|-----------------------|------------------------------|--|--------------------------------------|-------------------------|------------------------|
| | | | | | | HT (T1) Head/Drive/Bend mm | Low (T2) L.T.U mm | Low (T2) Tail mm |
| 2800 | 500 | 245 | 50 | 7.7 | 10.5 | 315 | 315 | 250 |
| 3300 | 580 | 245 | 58 | 8.0 | 10.7 | 355 | 355 | 315 |
| 3500 | 630 | 263 | 63 | 8.1 | 11.0 | 400 | 355 | 315 |
| 4000 | 700 | 263 | 70 | 8.4 | 11.0 | 400 | 355 | 355 |
| 4500 | 800 | 315 | 80 | 8.5 | 11.0 | 500 | 400 | 355 |
| 5000 | 875 | 320 | 87 | 9.0 | 11.3 | 500 | 400 | 355 |
| 6000 | 1050 | 350 | 105 | 9.6 | 11.7 | 630 | 450 | 400 |
| 6500 | 1140 | 350 | 114 | 9.6 | 12.1 | 630 | 450 | 400 |
| 7000 | 1250 | 350 | 125 | 10.5 | 13.0 | 750 | 500 | 450 |
| 8000 | 1400 | 350 | 140 | 11.3 | 14.4 | 750 | 500 | 450 |
| 9000 | 1600 | 450 | 160 | 12.2 | 15.1 | 800 | 630 | 600 |
| 10000 | 1750 | 450 | 175 | 13.1 | 15.9 | 800 | 630 | 600 |
| 12000 | 2100 | 450 | 210 | 14.0 | 18.5 | 1000 | 800 | 750 |
| 15000 | 2625 | 450 | 262 | 15.3 | 19.6 | 1250 | 900 | 800 |
| 18000 | 3150 | 450 | 315 | 17.6 | 23.8 | 1500 | 1000 | 1000 |

BELT DESIGNATION: Belts can be produced to various tensile specifications, using either polyamide or polyester base warp yarn. Some markets still prefer to specify belt types based on tensile strength expressed in lbs/in width (the Fenoplast Belt Designation uses this terminology), whilst others opt for the preferred ISO types expressed in kN/m.

BELT WEIGHTS: the above table exhibits typical figures for minimum warp and weft strengths, belt thickness and weight for a selection of belt types are based on 1x1mm PVC covers. For thicker covers, add 1.3 kg/m²/mm for PVC covers and 1.4 kg/m²/mm for rubber covers. The nominal figures quoted for thickness and weight are based on our specific belt construction.

ALTERNATIVE CONSTRUCTIONS: Many alternative constructions are available which give values higher than those in the table. This is particularly relevant to weft strength, where special yarns designs may be recommended for improved properties such fastener holding, load support, weft stability etc. The use of such special yarns may increase the belt weight and thickness which may be critical for shipping purposes or underground transportation. A FENNER DUNLOP engineer should always be consulted where this information is likely to be critical.

PULLEY DIAMETERS: The drum diameters are the minimum recommended without complete application details. With information regarding wrap configurations, tensions, belt speeds, jointing methods, etc.

Note: All technical information listed in the above table are typical values and should be used as a guide only

10. Steel Cord Belting

| | |
|-----------------------------------|---------------|
| Construction | 10 – 1 |
| Operating conditions | 10 – 2 |
| Belt covers | 10 – 6 |
| Belt protection | 10 – 6 |
| Splicing | 10 – 7 |

| | | |
|---------|--|--------|
| Table 1 | Australian Standard constructions | 10 – 1 |
| Table 2 | Special belt constructions | 10 – 2 |
| Table 3 | Operating conditions | 10 – 3 |
| Table 4 | Minimum transition lengths | 10 – 4 |
| Table 5 | Minimum belt width for troughing | 10 – 5 |
| Table 6 | Recommended take-up travel allowance | 10 – 6 |
| Table 7 | Splice details | 10 – 8 |

10. Steel cord belting

Steel cord belting is used on conveyors where high belt tension, available take-up travel or the requirement for a high elastic modulus dictates that a fabric belt is unsuitable. Steel cord belts also provide excellent splice efficiency for difficult pulley configurations and are able to accommodate smaller pulleys than plied fabric belts of similar working tension.

CONSTRUCTION

Steel cord belts are comprised of zinc coated steel cables embedded in a bonding rubber matrix with covers top and bottom as shown below:

FIG. 1
BELT CONSTRUCTION

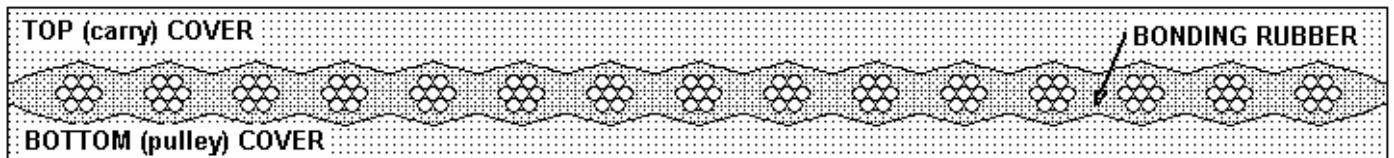

Cord spacing and diameter are varied to provide the required strength. There are various international and industry standards for belt construction and some of these are shown below. Available belt covers and belt grades are shown in *Section 1*.

TABLE 1
AUSTRALIAN STANDARD AS1333
BELT CONSTRUCTIONS

| Designation (kN/m) | Min cover thickness (mm) | Cords | | Belt mass | | Belt thickness (mm) |
|-----------------------|--------------------------------|------------------|-----------------|----------------------------------|---------------------------------|---------------------------|
| | | Diameter (mm) | Spacing (mm) | Standard (kg/m ²) | Grade S (kg/m ²) | |
| ST500 | 4 | 2.6 | 13.8 | 14.1 | 16.3 | 10.6 |
| ST560 | 4 | 2.8 | 13.8 | 14.7 | 16.9 | 10.8 |
| ST630 | 4 | 3.0 | 13.8 | 15.2 | 17.4 | 11 |
| ST710 | 4 | 3.1 | 13.8 | 15.5 | 17.6 | 11.1 |
| ST800 | 4 | 3.4 | 13.8 | 16.4 | 18.5 | 11.4 |
| ST900 | 4 | 3.8 | 15.3 | 17.2 | 19.3 | 11.8 |
| ST1000 | 4 | 4.0 | 15.3 | 17.9 | 20.0 | 12 |
| ST1120 | 4 | 4.2 | 15.3 | 18.4 | 20.5 | 12.2 |
| ST1250 | 5 | 4.5 | 15.3 | 21.8 | 24.4 | 14.5 |
| ST1400 | 5 | 4.8 | 15.3 | 22.7 | 25.3 | 14.8 |
| ST1600 | 5 | 5.5 | 17.3 | 24.4 | 27.0 | 15.5 |
| ST1800 | 5 | 6.0 | 17.3 | 25.9 | 28.5 | 16 |
| ST2000 | 5 | 6.4 | 17.3 | 27.2 | 29.8 | 16.4 |
| ST2240 | 5 | 6.8 | 17.3 | 28.8 | 31.4 | 16.8 |
| ST2500 | 6 | 7.4 | 19.4 | 32.4 | 35.4 | 19.4 |
| ST2800 | 6 | 8.0 | 19.4 | 34.3 | 37.4 | 20 |
| ST3150 | 6 | 8.6 | 19.4 | 36.8 | 39.9 | 20.6 |
| ST3550 | 7 | 9.2 | 19.4 | 41.3 | 44.8 | 23.2 |
| ST4000 | 7 | 9.8 | 19.4 | 43.7 | 47.2 | 23.8 |
| ST4500 | 8 | 10.4 | 19.4 | 48.7 | 52.7 | 26.4 |
| ST5000 | 8 | 11.0 | 19.4 | 51.2 | 55.2 | 27 |
| ST5600 | 9 | 11.8 | 19.4 | 57.4 | 61.8 | 29.8 |
| ST6300 | 9 | 12.8 | 20 | 61.1 | 65.5 | 30.8 |

**TABLE 2
SPECIAL BELT CONSTRUCTIONS**

| Designation (kN/m) | Min cover thickness (mm) | Cords | | Belt mass | | Belt thickness (mm) |
|-----------------------|--------------------------------|------------------|-----------------|----------------------------------|---------------------------------|---------------------------|
| | | Diameter (mm) | Spacing (mm) | Standard (kg/m ²) | Grade S (kg/m ²) | |

FIXED PITCH BELT CONSTRUCTIONS

| | | | | | | |
|--------|---|-----|----|------|------|------|
| ST800 | 4 | 3.2 | 12 | 14.7 | 16.9 | 11.2 |
| ST1000 | 4 | 3.8 | 12 | 16.0 | 18.2 | 11.8 |
| ST1250 | 4 | 4.0 | 12 | 16.6 | 18.7 | 12 |
| ST1600 | 5 | 4.6 | 12 | 20.3 | 22.9 | 14.6 |
| ST2000 | 5 | 5.2 | 12 | 21.8 | 24.4 | 15.2 |
| ST2500 | 5 | 5.6 | 12 | 22.9 | 25.6 | 15.6 |

DIN BELT CONSTRUCTIONS

| | | | | | | |
|--------|---|------|----|------|------|------|
| ST1000 | 4 | 3.6 | 12 | 17.3 | 19.4 | 11.6 |
| ST1250 | 4 | 4.4 | 14 | 19.6 | 21.7 | 12.4 |
| ST1600 | 5 | 5.2 | 15 | 24.1 | 26.7 | 15.2 |
| ST2000 | 5 | 5.2 | 12 | 25.4 | 28.0 | 15.2 |
| ST2500 | 5 | 6.8 | 15 | 30.0 | 32.6 | 16.8 |
| ST3150 | 6 | 7.6 | 15 | 35.7 | 38.7 | 19.6 |
| ST3500 | 6 | 8.2 | 15 | 38.2 | 41.2 | 20.2 |
| ST4000 | 6 | 8.6 | 15 | 40.2 | 43.1 | 20.6 |
| ST4500 | 7 | 9.6 | 16 | 45.9 | 49.3 | 23.6 |
| ST5000 | 8 | 10.6 | 17 | 51.6 | 55.5 | 26.6 |
| ST5400 | 8 | 11.0 | 17 | 53.5 | 57.4 | 27 |

For each additional millimetre of belt cover to the above belt weight add:

(additional cover x cover factor*) kg/m²

*Cover factor from Section 8, page 8-6, Table 3

The tables above show the most common range of belts however belt strengths up to ST8000 are available. Belts above the strengths shown above are generally purpose designed for the specific installation.

OPERATING CONDITIONS

Allowable working tension

The accepted safety factor for steel cord belting is 6.7:1, which is shown in Table 3, however considerably lower safety factors can be accommodated on installations with well controlled starts and long time cycles, and where transient or peak tensions are low.

Conversely, adverse operating conditions may dictate that a higher safety factor is applied. For details refer to *Section 4, page 4-1 Operating Conditions*.

Pulley diameters

Pulley diameters are shown on Table 3, for belts operating at over 60% of allowable working tension and for belts operating at 30 to 60% of allowable working tension. Where belts are operating at less than 30% of allowable working tension, the diameter of Type A high tension pulleys can be reduced to the same diameter as Type B pulleys.

Crowned pulleys should NOT be used with steel cord belting.

**TABLE 3
OPERATING CONDITIONS**

| Designation (kN/m) | Allowable working tension (kN/m) | Elastic modulus (kN/m) | Minimum pulley diameters | | | | | |
|-----------------------|---|------------------------------|--|----------------|----------------|---|----------------|----------------|
| | | | Belts operating at 60 - 100% of allowable working tension | | | Belts operating at 30 - 60% of allowable working tension | | |
| | | | Type A (mm) | Type B (mm) | Type C (mm) | Type A (mm) | Type B (mm) | Type C (mm) |

AS1333 BELT CONSTRUCTIONS

| | | | | | | | | |
|--------|-------|--------|------|------|------|------|------|------|
| ST500 | 75 | 36000 | 400 | 315 | 250 | 315 | 250 | 200 |
| ST560 | 84 | 40320 | 450 | 360 | 280 | 360 | 280 | 225 |
| ST630 | 94.5 | 45360 | 450 | 360 | 280 | 360 | 280 | 225 |
| ST710 | 106.5 | 51120 | 500 | 400 | 315 | 400 | 315 | 250 |
| ST800 | 120 | 57600 | 500 | 400 | 315 | 400 | 315 | 250 |
| ST900 | 135 | 64800 | 560 | 450 | 360 | 450 | 360 | 280 |
| ST1000 | 150 | 72000 | 630 | 500 | 400 | 500 | 400 | 315 |
| ST1120 | 168 | 80640 | 630 | 500 | 400 | 500 | 400 | 315 |
| ST1250 | 187.5 | 90000 | 710 | 560 | 450 | 560 | 450 | 360 |
| ST1400 | 210 | 100800 | 710 | 560 | 450 | 560 | 450 | 360 |
| ST1600 | 240 | 115200 | 800 | 630 | 500 | 630 | 500 | 400 |
| ST1800 | 270 | 129600 | 900 | 710 | 560 | 710 | 560 | 450 |
| ST2000 | 300 | 144000 | 1000 | 800 | 630 | 800 | 630 | 500 |
| ST2240 | 336 | 161280 | 1000 | 800 | 630 | 800 | 630 | 500 |
| ST2500 | 375 | 180000 | 1120 | 900 | 710 | 900 | 710 | 560 |
| ST2800 | 420 | 201600 | 1250 | 1000 | 800 | 1000 | 800 | 630 |
| ST3150 | 472.5 | 226800 | 1250 | 1000 | 800 | 1000 | 800 | 630 |
| ST3550 | 532.5 | 255600 | 1400 | 1120 | 900 | 1120 | 900 | 710 |
| ST4000 | 600 | 288000 | 1400 | 1120 | 900 | 1120 | 900 | 710 |
| ST4500 | 675 | 324000 | 1600 | 1250 | 1000 | 1250 | 1000 | 800 |
| ST5000 | 750 | 360000 | 1600 | 1250 | 1000 | 1250 | 1000 | 800 |
| ST5600 | 840 | 403200 | 1800 | 1400 | 1120 | 1400 | 1120 | 900 |
| ST6300 | 945 | 453600 | 2000 | 1600 | 1250 | 1600 | 1250 | 1000 |

FIXED PITCH BELT CONSTRUCTIONS

| | | | | | | | | |
|--------|-------|--------|-----|-----|-----|-----|-----|-----|
| ST800 | 120 | 57600 | 500 | 400 | 315 | 400 | 315 | 250 |
| ST1000 | 150 | 72000 | 560 | 450 | 360 | 450 | 360 | 280 |
| ST1250 | 187.5 | 90000 | 630 | 500 | 400 | 500 | 400 | 315 |
| ST1600 | 240 | 115200 | 710 | 560 | 450 | 560 | 450 | 360 |
| ST2000 | 300 | 144000 | 800 | 630 | 500 | 630 | 500 | 400 |
| ST2500 | 375 | 180000 | 900 | 710 | 560 | 710 | 560 | 450 |

DIN BELT CONSTRUCTONS

| | | | | | | | | |
|--------|-------|--------|------|------|------|------|------|-----|
| ST1000 | 150 | 72000 | 560 | 450 | 360 | 450 | 360 | 280 |
| ST1250 | 187.5 | 90000 | 630 | 500 | 400 | 500 | 400 | 315 |
| ST1600 | 240 | 115200 | 800 | 630 | 500 | 630 | 500 | 400 |
| ST2000 | 300 | 144000 | 800 | 630 | 500 | 630 | 500 | 400 |
| ST2500 | 375 | 180000 | 1000 | 800 | 630 | 800 | 630 | 500 |
| ST3150 | 472.5 | 226800 | 1120 | 900 | 710 | 900 | 710 | 560 |
| ST3500 | 525 | 252000 | 1250 | 1000 | 800 | 1000 | 800 | 630 |
| ST4000 | 600 | 288000 | 1250 | 1000 | 800 | 1000 | 800 | 630 |
| ST4500 | 675 | 324000 | 1400 | 1120 | 900 | 1120 | 900 | 710 |
| ST5000 | 750 | 360000 | 1600 | 1250 | 1000 | 1250 | 1000 | 800 |
| ST5400 | 810 | 388800 | 1600 | 1250 | 1000 | 1250 | 1000 | 800 |

Transition lengths

Terminal pulleys at head and discharge ends of a conveyor or at a tripper are most commonly located at half the trough depth above the centre idler roller. The tail end pulley is most often located in line with the centre idler roller – as shown below.

Further explanation and information is shown in *Section 7 – Design Considerations*.

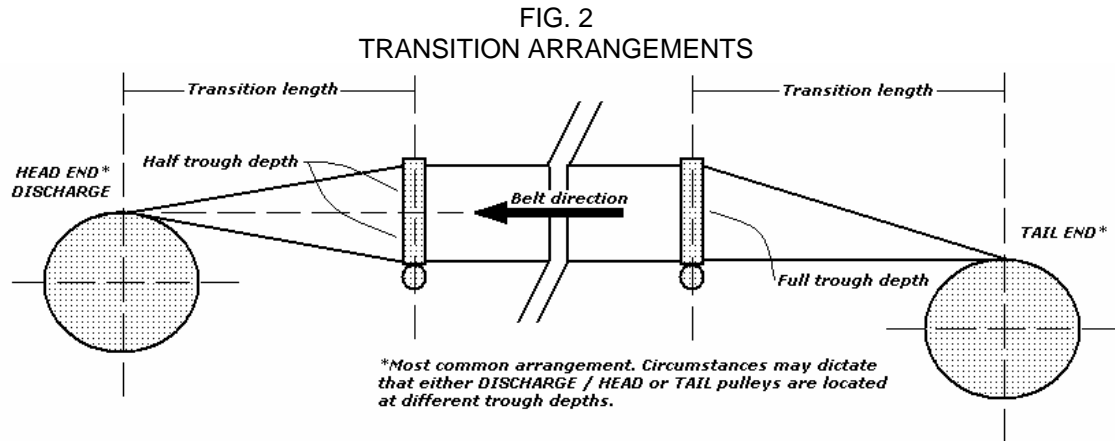

Table 4 below lists the transition lengths required for the most common trough angles for three roll equal length idlers. The transition length can be determined by multiplying the belt width by the factor below. Longer transitions are required at increased belt tension, however at very low tensions; longer transitions are also required to maintain positive tension in the centre of the belt.

**TABLE 4
TRANSITION LENGTHS**

TRANSITION LENGTH FACTOR (times belt width)

| Utilization (% max allowable working tension) | Full trough | | | Half trough | | |
|---|-------------|-----|-----|-------------|-----|-----|
| | 20° | 35° | 45° | 20° | 35° | 45° |
| 100% | 3.5 | 6.0 | 7.5 | 1.7 | 3.0 | 3.7 |
| 95% | 3.2 | 5.4 | 6.8 | 1.6 | 2.7 | 3.4 |
| 90% | 3.0 | 5.0 | 6.3 | 1.5 | 2.5 | 3.2 |
| 85% | 2.7 | 4.7 | 5.8 | 1.4 | 2.3 | 2.9 |
| 80% | 2.5 | 4.3 | 5.4 | 1.3 | 2.2 | 2.7 |
| 75% | 2.4 | 4.1 | 5.2 | 1.2 | 2.1 | 2.6 |
| 70% | 2.3 | 3.9 | 4.9 | 1.1 | 1.9 | 2.5 |
| 65% | 2.2 | 3.7 | 4.7 | 1.1 | 1.9 | 2.3 |
| 60% | 2.1 | 3.6 | 4.5 | 1.0 | 1.8 | 2.3 |
| 55% | 2.1 | 3.5 | 4.4 | 1.0 | 1.8 | 2.2 |
| 50% | 2.1 | 3.5 | 4.4 | 1.0 | 1.7 | 2.2 |
| 45% | 2.0 | 3.4 | 4.3 | 1.0 | 1.7 | 2.2 |
| 40% | 2.0 | 3.4 | 4.2 | 1.0 | 1.7 | 2.1 |
| 35% | 2.1 | 3.5 | 4.4 | 1.0 | 1.7 | 2.2 |
| 30% | 2.1 | 3.6 | 4.5 | 1.0 | 1.8 | 2.3 |
| 25% | 2.3 | 4.0 | 5.0 | 1.2 | 2.0 | 2.5 |
| 20% | 2.6 | 4.5 | 5.6 | 1.3 | 2.2 | 2.8 |
| 15% | 3.1 | 5.3 | 6.6 | 1.5 | 2.6 | 3.3 |
| 10% | 3.9 | 6.6 | 8.3 | 2.0 | 3.3 | 4.2 |

Load support and troughability

Load support is normally not an issue however for steeply troughed, wide belts or light belts with heavy materials or very large lumps, please contact your Fenner Dunlop representative. Fitment of a transverse breaker can provide necessary increased stiffness.

Carrying idler spacing (refer Section 3), should limit sag between idlers to 1.5% for lumps up to 200mm and light materials. For very heavy materials and lumps over 200mm, sag should be limited to 1% of idler spacing. The gap between idler rollers should not exceed 15mm to avoid pinching and belt wear at the idler junction.

Minimum belt width for troughing is influenced by belt construction and thickness of covers and the following table provides a guide. Where a belt incorporates a transverse breaker, add 150mm to the belt width for a single breaker and 300mm where there are two breakers. If in doubt, contact your Fenner Dunlop representative.

**TABLE 5
MINIMUM BELT WIDTH FOR TROUGHING**

| Designation (kN/m) | Minimum belt width for Trough Angle (mm) | | |
|-----------------------|---|------|------|
| | 20° | 35° | 45° |
| ST500 | 600 | 600 | 600 |
| ST560 | 600 | 600 | 600 |
| ST630 | 600 | 600 | 600 |
| ST710 | 600 | 600 | 600 |
| ST800 | 600 | 600 | 750 |
| ST900 | 600 | 600 | 750 |
| ST1000 | 600 | 600 | 750 |
| ST1120 | 600 | 750 | 900 |
| ST1250 | 600 | 750 | 900 |
| ST1400 | 600 | 750 | 900 |
| ST1600 | 750 | 750 | 900 |
| ST1800 | 750 | 900 | 900 |
| ST2000 | 750 | 900 | 900 |
| ST2240 | 750 | 900 | 900 |
| ST2500 | 750 | 900 | 900 |
| ST2800 | 750 | 900 | 900 |
| ST3150 | 750 | 900 | 900 |
| ST3550 | 900 | 900 | 1050 |
| ST4000 | 900 | 900 | 1050 |
| ST4500 | 900 | 900 | 1050 |
| ST5000 | 900 | 1050 | 1200 |
| ST5600 | 900 | 1050 | 1200 |
| ST6300 | 900 | 1050 | 1200 |

Take-up Travel

Recommended take-up travel allowances for most circumstances are shown in Table 6 below:

**TABLE 6
RECOMMENDED TAKE-UP TRAVEL
ALLOWANCE**

| Conveyor centres (metres) | Take-up travel (% of centres) |
|------------------------------|----------------------------------|
| 150 | 0.80% |
| 300 | 0.70% |
| 500 | 0.60% |
| 750 | 0.50% |
| 1000 | 0.45% |
| 1500 | 0.40% |
| 2000 | 0.30% |
| 3000 | 0.25% |

With proper tensioning of the belt during the closing splice operation and careful control of starting and stopping, take-up travel can be as small as 0.25% of the conveyor centre distance, which will accommodate:

- 0.05% thermal expansion and contraction
- 0.05% permanent stretch
- 0.15% elastic elongation

BELT COVERS

Cover types

The range of belt covers available is shown in *Section 1*.

In addition to this range of cover compounds, Fenner Dunlop offer a complete range of specialised "Low Rolling Resistance" pulley cover compounds under the brand name "**PowerPlus**". On long-centre horizontal conveyors these compounds help reduce total system power consumption and operating costs.

Cover thickness

As a guide, Top Cover thickness may be determined by adding the plied belt cover thickness from Section 5 – Table 1, to the minimum cover thickness shown in Tables 1 and 2 above.

Pulley Cover thickness may be increased from the minimum thickness shown in Tables 1 and 2 by 1 - 3mm depending on the application and the condition of the installation. In any event, the Pulley Cover should be no less than one third of the thickness of the carrying cover.

BELT PROTECTION

Steel cord belting is more vulnerable to longitudinal ripping than fabric belting as there is no weft tension member or reinforcement.

Transverse reinforcement

Various types of transverse reinforcement can be incorporated into either the top or bottom belt covers, or both covers. These may include woven breakers, designed to prevent penetration, or transverse cords to prevent ripping and eject any tramp material that has penetrated the belt, or both.

Rip detection

Electronic and electromagnetic systems can be incorporated in the belt to enable a rip to be detected and the conveyor stopped to prevent further damage. Fenner Dunlop's "**EagleEye**" system is available to also provide continuous condition monitoring which will detect and monitor such defects as damaged or corroded cords while at the same time providing rip detection.

For details of available options, please contact your Fenner Dunlop representative.

SPLICING

Steel cord belts are made endless by a hot vulcanised splice with cords overlapped from each end in a symmetrical pattern which is determined by the cord spacing and cord diameter.

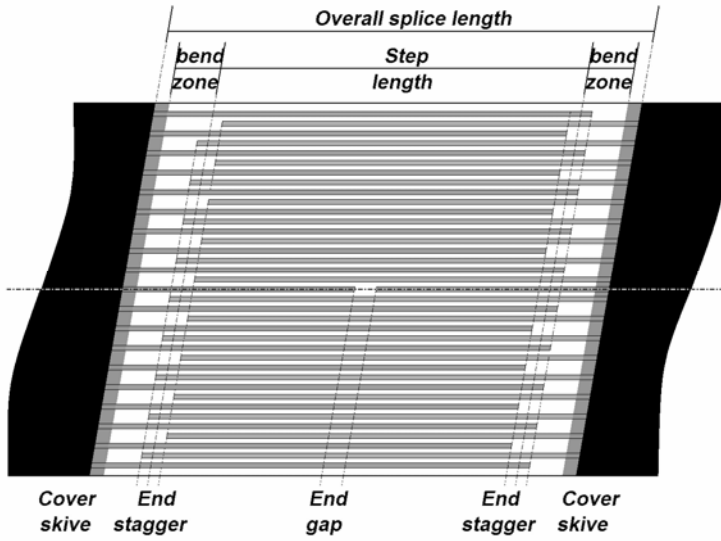

Fig. 3A – Single step splice

Fig. 3B – Two step splice

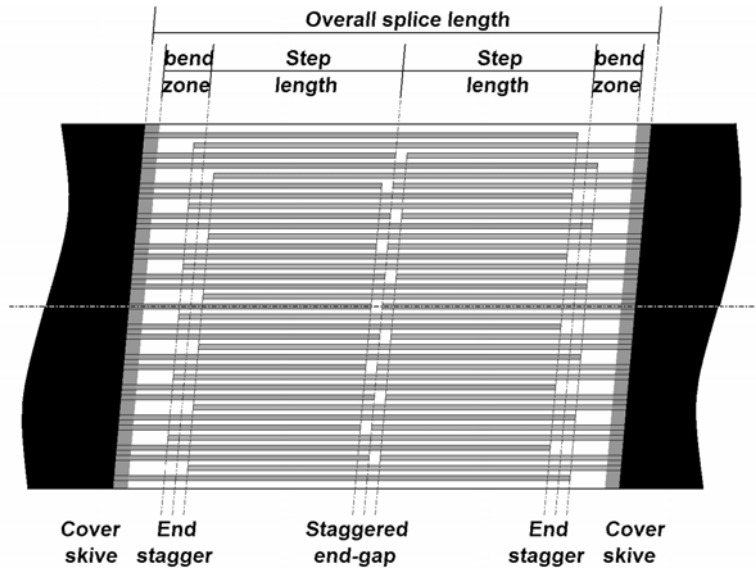
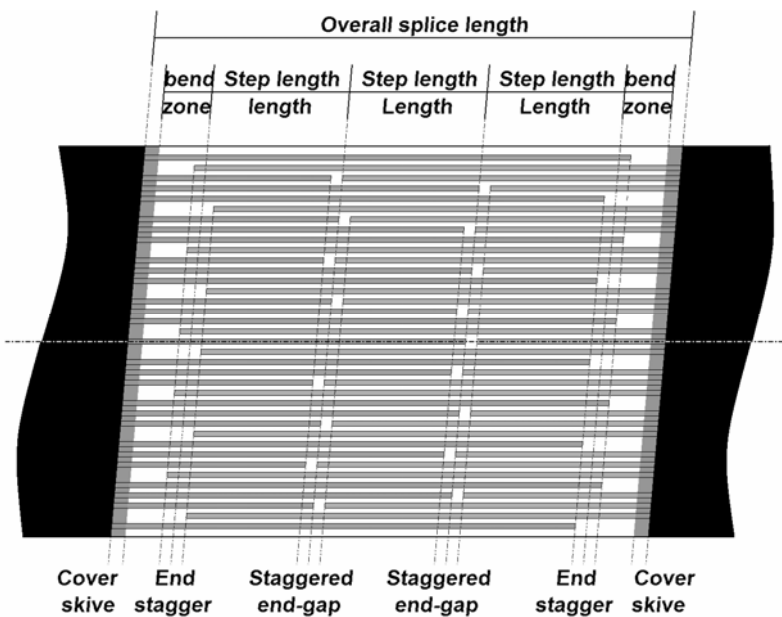

Fig. 3C – Three step splice



Higher strength belts with heavier cords require more steps to ensure that there is a sufficient gap between cords in the splice.

Very heavy belts – up to ST8000 require specially designed splices.

**TABLE 7
SPLICE DETAILS**

| AS1333 BELT CONSTRUCTIONS | | | | SPECIAL BELT CONSTRUCTIONS | | | | | |
|----------------------------------|--------------------------------------|-------------------|----------------------|-----------------------------------|--------------------------------------|------------------|----------------------|--|--|
| Designation (kN/m) | Splice type | Splice length | Total step length | Designation (kN/m) | Splice type | Splice length | Total step length | | |
| | | (mm) | (mm) | | | (mm) | (mm) | | |
| ST500 | single step | 700 | 400 | FIXED PITCH CONSTRUCTIONS | | | | | |
| ST560 | | 700 | 400 | ST800 | single step | 800 | 500 | | |
| ST630 | | 750 | 450 | ST1000 | | 850 | 550 | | |
| ST710 | | 750 | 450 | ST1250 | | 900 | 600 | | |
| ST800 | | 800 | 500 | ST1600 | two step | 1450 | 1100 | | |
| ST900 | | 850 | 550 | ST2000 | | 1600 | 1250 | | |
| ST1000 | | 900 | 600 | ST2500 | | 1700 | 1350 | | |
| ST1120 | | 950 | 650 | DIN BELT CONSTRUCTIONS | | | | | |
| ST1250 | | 950 | 650 | ST1000 | single step | 850 | 550 | | |
| ST1400 | | 1000 | 700 | ST1250 | | 950 | 650 | | |
| ST1600 | | 1100 | 800 | ST1600 | | 1050 | 750 | | |
| ST1800 | | 1150 | 850 | ST2000 | two step | 1600 | 1250 | | |
| ST2000 | | 1200 | 900 | ST2500 | | 2000 | 1650 | | |
| ST2240 | | 1300 | 1000 | ST3150 | 2200 | 1850 | | | |
| ST2500 | | 1450 | 1150 | ST3500 | three step | 2700 | 2300 | | |
| ST2800 | two step | 2300 | 1950 | ST4000 | | 2850 | 2450 | | |
| ST3150 | | 2400 | 2050 | ST4500 | | 3100 | 2700 | | |
| ST3550 | | 2550 | 2200 | ST5000 | <i>contact us for recommendation</i> | | | | |
| ST4000 | | 2700 | 2350 | ST5400 | <i>contact us for recommendation</i> | | | | |
| ST4500 | | 2900 | 2550 | | | | | | |
| ST5000 | | three step | 3500 | 3100 | | | | | |
| ST5600 | 3650 | | 3250 | | | | | | |
| ST6300 | <i>contact us for recommendation</i> | | | | | | | | |

MANUFACTURING PLANTS

West Footscray

Fenner Dunlop Australia
268 Geelong Road
West Footscray Vic 3012
Phone (03) 9680 4500
Fax (03) 9680 4595

Revesby

Fenner Dunlop Australia
81 Milperra Road,
Revesby NSW 2212
Phone (02) 9773 0411
Fax (02) 9772 1808

Kwinana

Fenner Dunlop Conveyor Belting
11 Mounsey Road
Kwinana Beach, WA 6167
Phone (08) 9439 7300
Fax (08) 94397399

BRANCHES

QUEENSLAND

Brisbane

Fenner Dunlop Conveyor Services
Unit 19, 190 Station Road
Yeerongpilly, Qld. 4105
Phone (07) 3392 9400
Fax (07) 3392 9411

Cairns

Fenner Dunlop Conveyor Services
6-8 Atticus Street
Cairns, Qld 4870
Phone (07) 4054 5211
Fax (07) 4054 5260

Emerald

Fenner Dunlop Conveyor Services
18 Kyle Street
Emerald, Qld 4720
Phone (07) 4982 4577
Fax (07) 4982 4401

Gladstone

Fenner Dunlop Conveyor Services
7 Bensted Street
Gladstone, Qld 4680
Phone (07) 4972 2155
Fax (07) 4972 2664

Mackay

Fenner Dunlop Conveyor Services
18 John Vella Drive
Paget, Qld 4740
Phone (07) 4940 7900
Fax (07) 4940 7990

Townsville

Fenner Dunlop Conveyor Services
614 Ingham Road
Garbutt, Qld 4814
Phone (07) 4774 8238
Fax (07) 4774 8239

Rockhampton

Fenner Dunlop Conveyor Services
82 McLaughlin Street
North Rockhampton Qld 4701
Phone (07) 4936 1244
Fax (07) 4936 1255

Mt Isa Region

Fenner Dunlop Conveyor Services
27-29 Commercial Road
Mount Isa, Qld 4825
Phone (07) 4144 0101
Fax (07) 4743 7042

NORTHERN TERRITORY

Darwin

Fenner Dunlop Conveyor Services
4 Butler Place
Berrimah, NT 0828
Phone (08) 8932 3111
Fax (08) 8932 3330

WESTERN AUSTRALIA

Perth

Fenner Dunlop Conveyor Services
11 Mounsey, Road
Kwinana Beach, WA 6167
Phone (08) 9439 7300
Fax (08) 94397399

Port Hedland

Lot 1025, Pinnacles Street
Wedgefield, WA 6724
Phone (08) 9172 5560
Fax (08) 9172 5373

Karratha

Fenner Dunlop Conveyor Services
Unit 3, 4514 Crane Circle
Karratha, WA 6714
Phone (08) 9185 1298
Fax (08) 9183 8552

SOUTH AUSTRALIA

Adelaide

Fenner Dunlop Conveyor Services
151 William Street
Beverley, SA 5009
Phone (08) 8268 4255
Fax (08) 8347 1087

Whyalla

Northern Belting Specialists
Shiell Street
Whyalla, SA 5600
Phone (08) 8644 0322
Fax (08) 8644 1533

NEW SOUTH WALES

Sydney

Fenner Dunlop Conveyor Services
31 Eddie Road,
Minchinbury, NSW 2770
Phone (02) 9832 0755
Fax (02) 9832 2400

Wollongong

Fenner Dunlop Conveyor Services
11 Luso Drive
Unanderra, NSW 2526
Phone (02) 4272 9266
Fax (02) 4272 9223

Hunter Region

Fenner Dunlop Conveyor Services
Unit 4 / 1 Kullara Close
Beresfield, NSW 2322
Phone (02) 4964 1766
Fax (02) 4966 0742

DISTRIBUTORS

Brisbane

Leading Edge Conveying
Solutions Pty Ltd
Unit 8, 227 Fleming Road
Hemmant, Qld 4174
Phone (07) 3907 3200
Fax (07) 3348 9772

Tasmania

Statewide Belting
39 Scarfe Street
Burnie Tas, 7320
Phone (03) 6435 2205
Fax (03) 6435 1929

Hunter Region

rEscan International
Units 1 & 2, 14 Accolade Avenue
Morrisett, NSW 2264
Phone (02) 4973 2399
Fax (02) 4970 4061

Victoria

Belle Banne (Victoria) Pty Ltd
63 - 75 Villas Road
Dandenong South, Vic 3175
Phone (03) 9768 4333
Fax (03) 9768 3370

New Zealand

Applied Conveyors & Polymers Pty Ltd
21 Holmes Road
Manurewa, Auckland
Phone +64 (09) 267 6070
Fax +64 (09) 267 6080